



ITEM NO: I07-412-WBR/PEP/BLK	Queen Panel HB
I07-400-WBR/PEP/BLK	Queen Sleigh HB
I07-402-WBR/PEP/BLK	Queen Rails
I07-403-WBR/PEP/BLK	Queen Low Profile FB

Thank you for purchasing this quality product. Be sure to check all packing material carefully for small parts that may come loose inside the carton during shipment.



UNIT SHOULD BE INSTALLED BY 2 OR MORE PERSONS.

OPTION 1: Queen LP Panel Bed

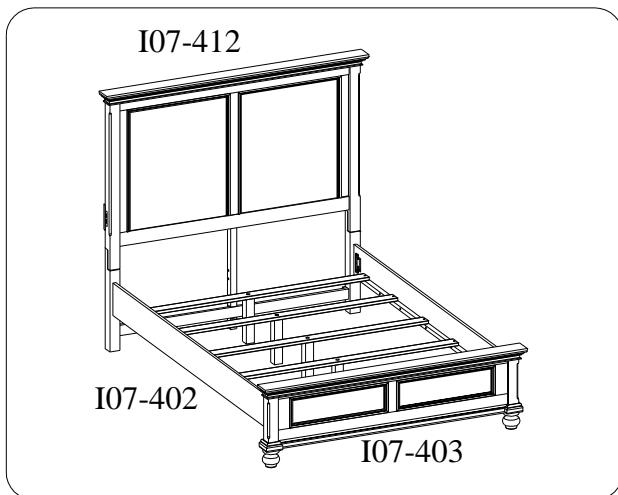

All Beds need to be set up in the exact final location so that after full assembly it will not need to be moved. Moving the bed will cause the support legs to move out of perpendicular (90 degree), weaken the support system, and may allow the bed to collapse.

OPTION 2: Queen LP Sleigh Bed

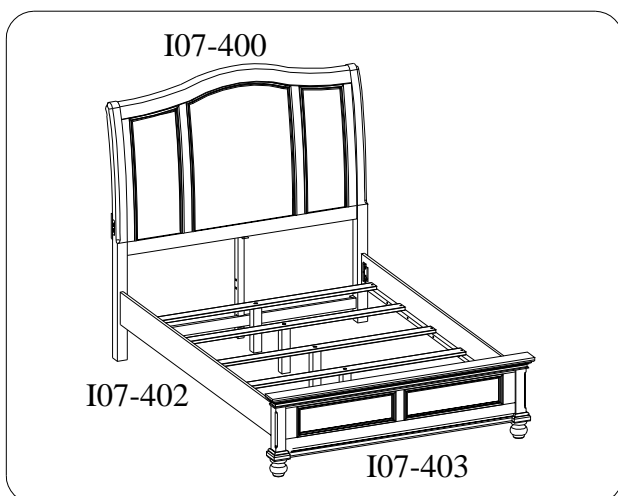

BEFORE USING THIS PRODUCT PLEASE READ, UNDERSTAND, AND FOLLOW THESE INSTRUCTIONS.
Save these instructions for future reference.

FOR INDOOR USE ONLY



ITEM NO: I07-412-WBR/PEP/BLK Queen Panel HB
 I07-400-WBR/PEP/BLK Queen Sleigh HB
 I07-402-WBR/PEP/BLK Queen Rails
 I07-403-WBR/PEP/BLK Queen Low Profile FB

TOOLS REQUIRED (NOT PROVIDED)
PHILLIPS SCREWDRIVER

COMPONENTS LIST: I07-412			
No.	Description	Sketch	Quantity
1	Headboard		1 PC
2	Left Leg		1 PC
3	Right Leg		1 PC
4	Wood Stretcher		1 PC
5	Center Support Leg		1 PC

HARDWARE LIST: I07-412			
No.	Description	Sketch	Quantity
A	Bolt Ø5/16"*2"		6 PCS
B	Bolt Ø5/16"*1-9/16"		3 PCS
C	Bolt Ø5/16"*1-3/8"		4 PCS
D	Lock Washer Ø5/16"		13 PCS
E	Flat Washer Ø5/16" *3/4"		13 PCS
F	Allen Wrench 5mm		1 PC

COMPONENTS LIST: I07-400			
No.	Description	Sketch	Quantity
1	Headboard		1 PC
2	Left Leg		1 PC
3	Right Leg		1 PC
4	Wood Stretcher		1 PC
5	Center Support Leg		1 PC

HARDWARE LIST: I07-400			
No.	Description	Sketch	Quantity
G	Wood Dowel Ø3/8"*1-9/16"		8 PCS
H	Bolt Ø5/16"*1-9/16"		9 PCS
I	Bolt Ø5/16"*1-3/8"		4 PCS
J	Lock Washer Ø5/16"		13 PCS
K	Flat Washer Ø5/16" *3/4"		13 PCS
L	Allen Wrench 5mm		1 PC

COMPONENTS LIST: I07-402			
No.	Description	Sketch	Quantity
1	Bed rails		2 PC
2	Slats		4 PC

HARDWARE LIST: I07-402			
No.	Description	Sketch	Quantity
M	Wood Screw M4*1-3/16"		8 PCS
N	Hanger Bolt Ø5/16"*3-1/16"		8 PCS
O	Lock Washer Ø5/16"		8 PCS
P	Flat washer 5/16" x 5/8"		8 PCS
Q	Hex Nut Ø5/16"		8 PCS
R	Hex Wrench 90*25*2mm		1 PC

COMPONENTS LIST: I07-403			
No.	Description	Sketch	Quantity
1	Footboard		1 PC
2	Support leg (for slats)		4 PCS
3	Bun foot		2 PCS



ITEM NO: I07-412-WBR/PEP/BLK Queen Panel HB
 I07-400-WBR/PEP/BLK Queen Sleigh HB
 I07-402-WBR/PEP/BLK Queen Rails
 I07-403-WBR/PEP/BLK Queen Low Profile FB

OPTION 1: Queen LP Panel Bed

STEP 1: Put the headboard face down on a soft surface. Attach the left leg and right leg to headboard by using 6 bolts(A), lock washers(D) and flat washers(E).

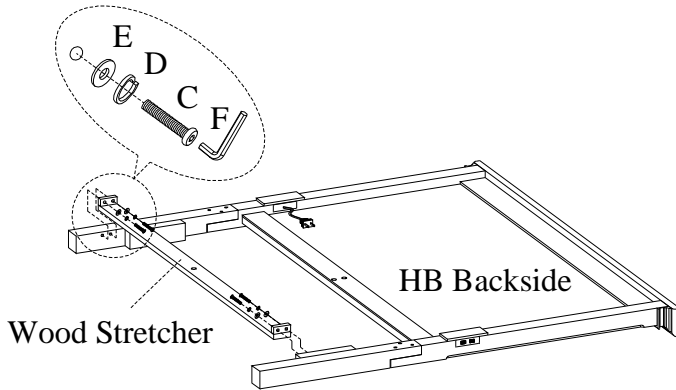
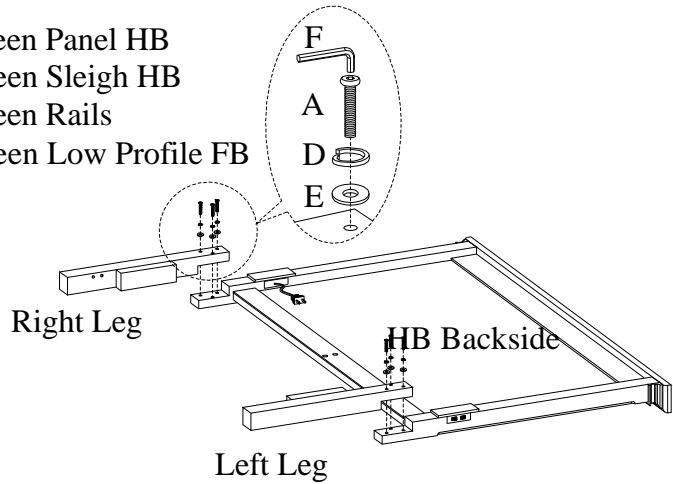

STEP 2: Attach the wood stretcher to the legs by using 4 bolts(C), lock washers(D) and flat washers(E).

STEP 3: Attach the center support leg to headboard and wood stretcher by using 3 bolts(B), lock washers(D) and flat washers(E).

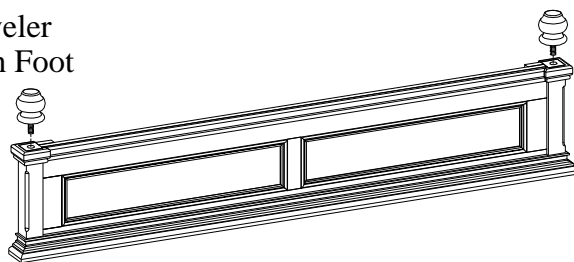
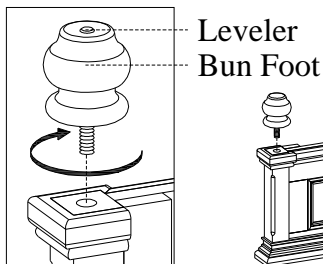
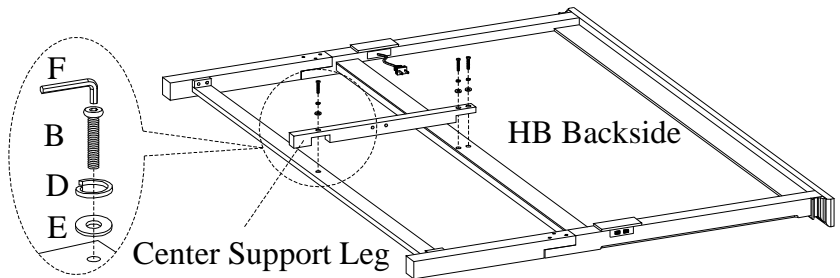

STEP 4: Put footboard upside down on a padded, clean surface. Attach bun feet to footboard. Turn footboard right side up.

STEP 5: The side rails may be used on either side. Arrange the side rails so the slat bearers are in LOWER POSITION prior to attachment in STEP 6.

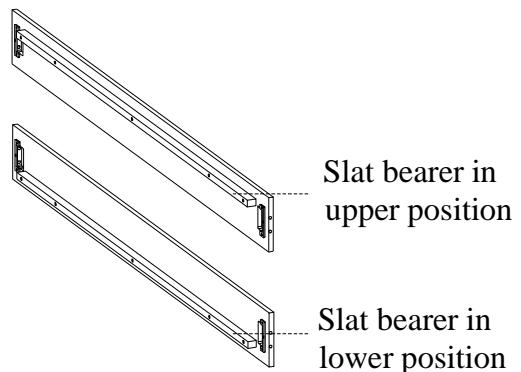



ITEM NO: I07-412-WBR/PEP/BLK Queen Panel HB
 I07-400-WBR/PEP/BLK Queen Sleigh HB
 I07-402-WBR/PEP/BLK Queen Rails
 I07-403-WBR/PEP/BLK Queen Low Profile FB

STEP 6: Screw the bolts(N) into HB & FB. Align the bolts with the holes in the end of side rails and attach the side rails to HB & FB using flat washer(P), lock washers(O) and nuts(Q). Then use a hex wrench(R) to tighten all the nuts.

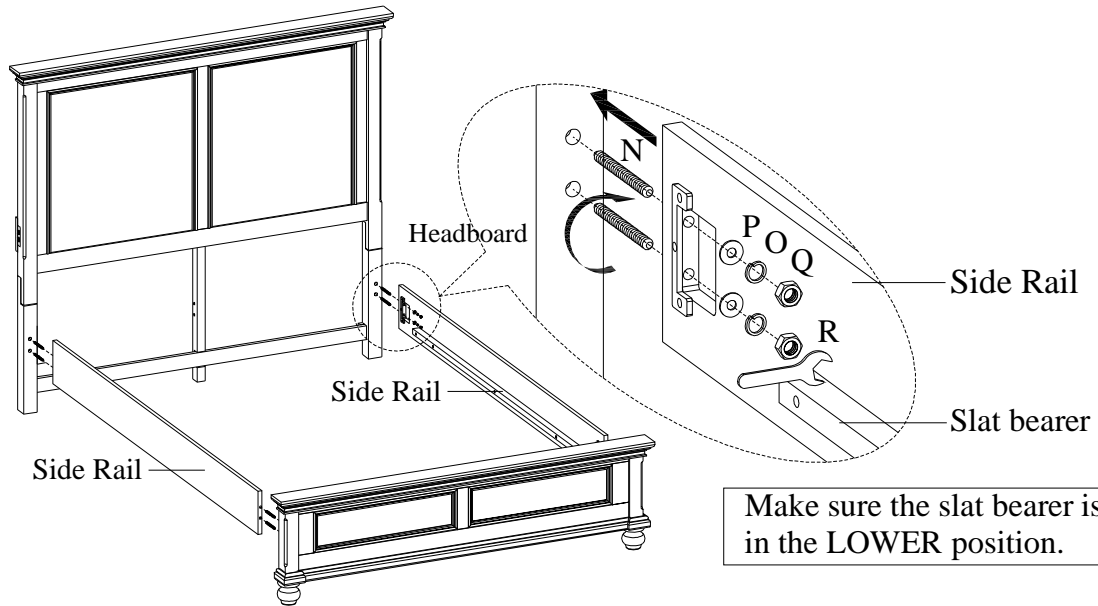

STEP 7: Attach the support legs with leveler to the slats. Adjust the levelers on bottom of support legs when necessary.

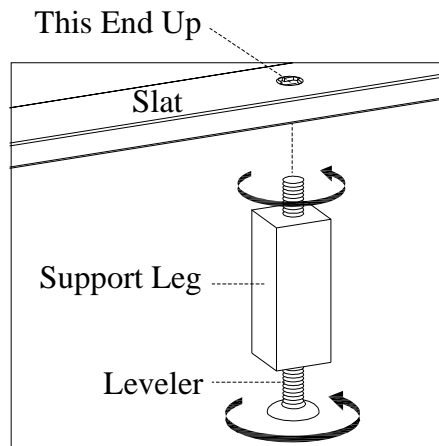
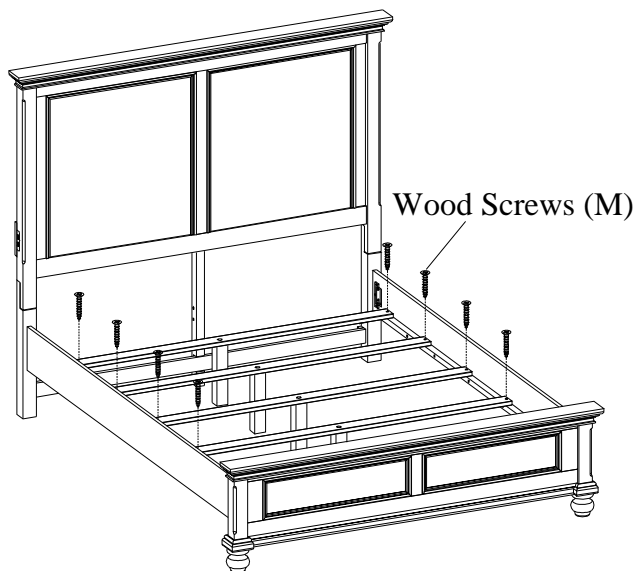

STEP 8: Arrange the slats on the slat bearer equally and attach to the slat bearer with wood screws (M).



ITEM NO: I07-412-WBR/PEP/BLK Queen Panel HB
 I07-400-WBR/PEP/BLK Queen Sleigh HB
 I07-402-WBR/PEP/BLK Queen Rails
 I07-403-WBR/PEP/BLK Queen Low Profile FB

OPTION 2: Queen LP Sleigh Bed

STEP 1: Put the headboard face down on a soft surface. Insert 8 wood dowels (G) into headboard, Then attach the left leg and right leg to headboard by using 6 bolts(H), lock washers(J) and flat washers(K).

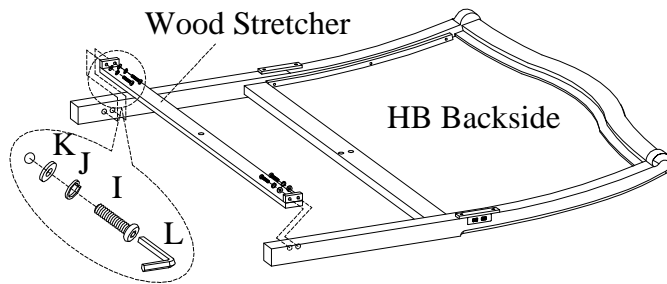
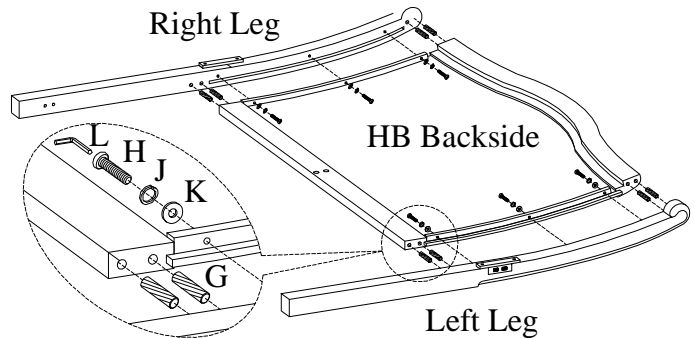

STEP 2: Attach the wood stretcher to the legs by using 4 bolts(I), lock washers(J) and flat washers(K).

STEP 3: Attach the center support leg to headboard and wood stretcher by using 3 bolts(H), lock washers(J) and flat washers(K).

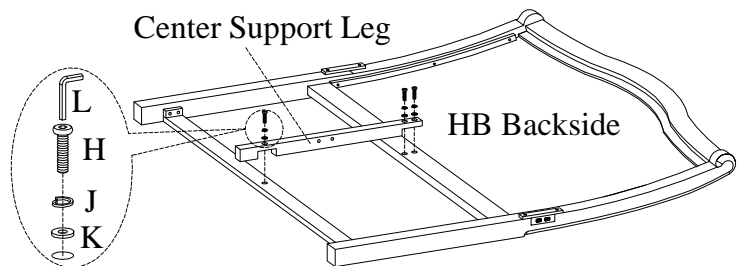

STEP 4 to STEP 11 are same as OPTION 1



ITEM NO: I07-412-WBR/PEP/BLK Queen Panel HB
I07-400-WBR/PEP/BLK Queen Sleigh HB
I07-402-WBR/PEP/BLK Queen Rails
I07-403-WBR/PEP/BLK Queen Low Profile FB

FUNCTIONALITY INSTRUCTION

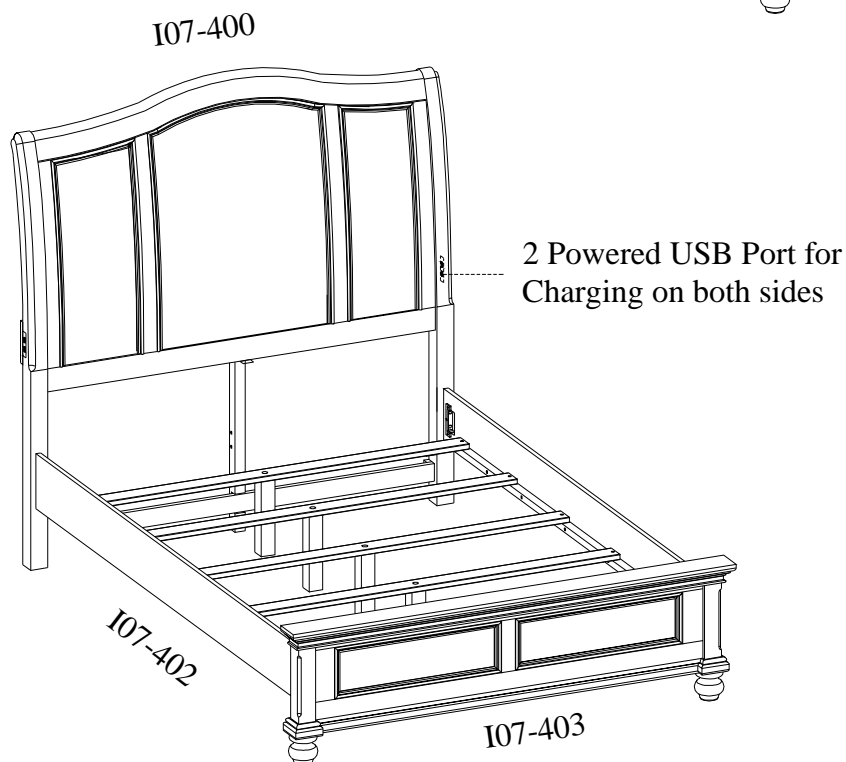
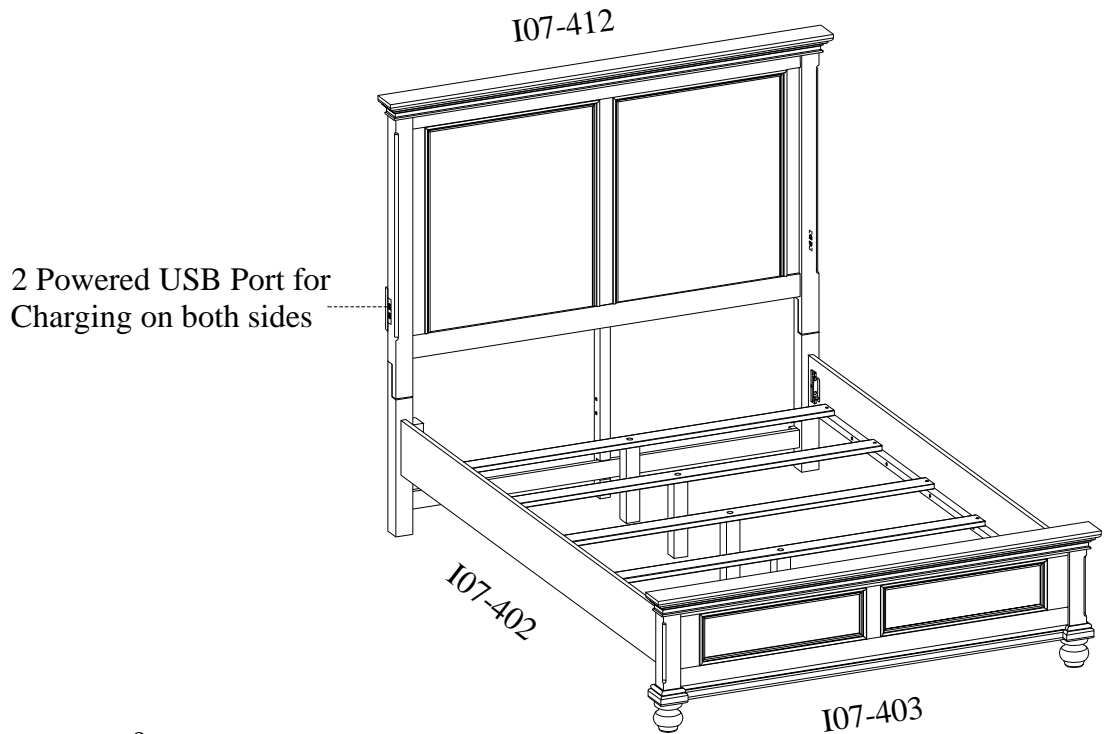



ITEM NO: I07-412-WBR/PEP/BLK Queen Panel HB
 I07-400-WBR/PEP/BLK Queen Sleigh HB
 I07-402-WBR/PEP/BLK Queen Rails
 I07-403D-WBR/PEP/BLK Queen Storage FB

Thank you for purchasing this quality product. Be sure to check all packing material carefully for small parts that may come loose inside the carton during shipment.



UNIT SHOULD BE INSTALLED BY 2 OR MORE PERSONS.

OPTION 1: Queen Storage Panel Bed

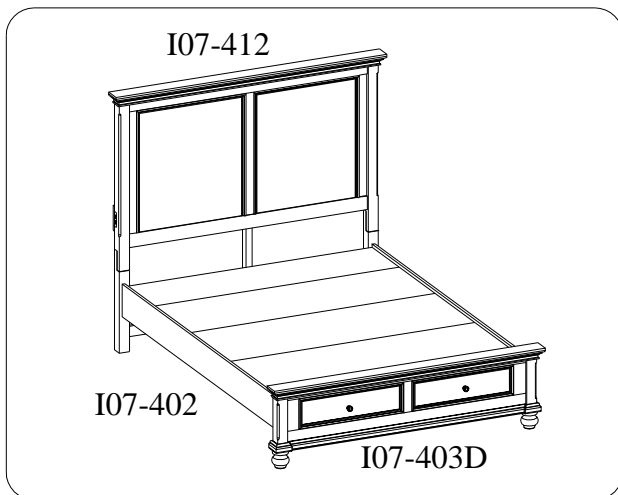

All Beds need to be set up in the exact final location so that after full assembly it will not need to be moved. Moving the bed will cause the support legs to move out of perpendicular (90 degree), weaken the support system, and may allow the bed to collapse.

OPTION 2: Queen Storage Sleigh Bed

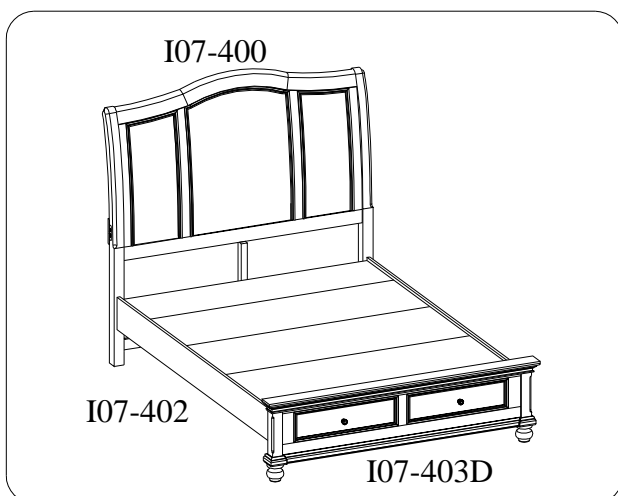

BEFORE USING THIS PRODUCT PLEASE READ, UNDERSTAND, AND FOLLOW THESE INSTRUCTIONS.
 Save these instructions for future reference.

FOR INDOOR USE ONLY



ITEM NO: I07-412-WBR/PEP/BLK Queen Panel HB
 I07-400-WBR/PEP/BLK Queen Sleigh HB
 I07-402-WBR/PEP/BLK Queen Rails
 I07-403D-WBR/PEP/BLK Queen Storage FB

TOOLS REQUIRED (NOT PROVIDED)

PHILLIPS SCREWDRIVER

HARDWARE LIST: I07-412

No.	Description	Sketch	Quantity
A	Bolt Ø5/16"*2"		6 PCS
B	Bolt Ø5/16"*1-9/16"		3 PCS
C	Bolt Ø5/16"*1-3/8"		4 PCS
D	Lock Washer Ø5/16"		13 PCS
E	Flat Washer Ø5/16" *3/4"		13 PCS
F	Allen Wrench 5mm		1 PC

HARDWARE LIST: I07-400

No.	Description	Sketch	Quantity
G	Wood Dowel Ø10*1-9/16"		8 PCS
H	Bolt Ø5/16"*1- 9/16"		9 PCS
I	Bolt Ø5/16"*1-3/8"		4 PCS
J	Lock Washer Ø5/16"		13 PCS
K	Flat Washer Ø5/16" *3/4"		13 PCS
L	Allen Wrench 5mm		1 PC

HARDWARE LIST: I07-402

No.	Description	Sketch	Quantity
M	Wood Screw M4*1-3/16"		8 PCS
N	Hanger Bolt Ø5/16"*3-1/16"		8 PCS
O	Lock Washer Ø5/16"		8 PCS
P	Flat washer 5/16 x 5/8"		8 PCS
Q	Hex Nut Ø5/16"		8 PCS
R	Hex Wrench 90*25*2mm		1 PC

HARDWARE LIST: I07-403D

No.	Description	Sketch	Quantity
S	Wood Screw M4*1		8 PCS
T	Bolt Ø5/16"*1-3/16"		8 PCS
U	Lock Washer Ø5/16"		8 PCS
V	Flat washer 5/16 x 3/4"		8 PCS
W	Allen Wrench 5mm		1 PC

COMPONENTS LIST: I07-412

No.	Description	Sketch	Quantity
1	Headboard		1 PC
2	Left Leg		1 PC
3	Right Leg		1 PC
4	Wood Stretcher		1 PC
5	Center Support Leg		1 PC

COMPONENTS LIST: I07-400

No.	Description	Sketch	Quantity
1	Headboard		1 PC
2	Left Leg		1 PC
3	Right Leg		1 PC
4	Wood Stretcher		1 PC
5	Center Support Leg		1 PC

COMPONENTS LIST: I07-402

No.	Description	Sketch	Quantity
1	Bed rails		2 PC
2	Slats		4 PC

COMPONENTS LIST: I07-403D

No.	Description	Sketch	Quantity
1	Footboard		1 PC
2	Support Leg (for center rail)		2 PCS
3	Support leg (for pedestal)		3 PCS
4	Decking		4 PCS
5	Center rail		1 PCS
6	Bun foot		2 PCS



ITEM NO: I07-412-WBR/PEP/BLK Queen Panel HB
 I07-400-WBR/PEP/BLK Queen Sleigh HB
 I07-402-WBR/PEP/BLK Queen Rails
 I07-403D-WBR/PEP/BLK Queen Storage FB

OPTION 1: Queen Storage Panel Bed

STEP 1: Put the headboard face down on a soft surface. Attach the left leg and right leg to headboard by using 6 bolts(A), lock washers(D) and flat washers(E).

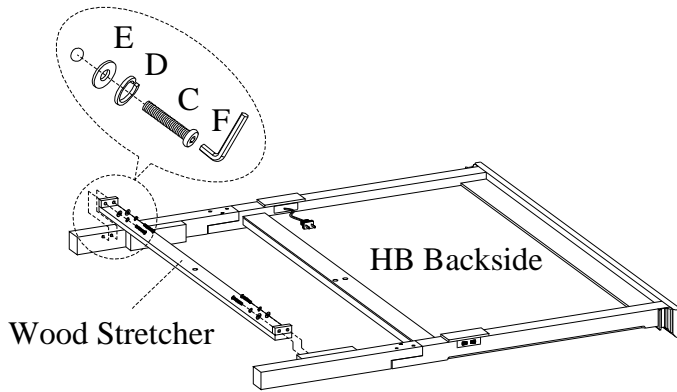
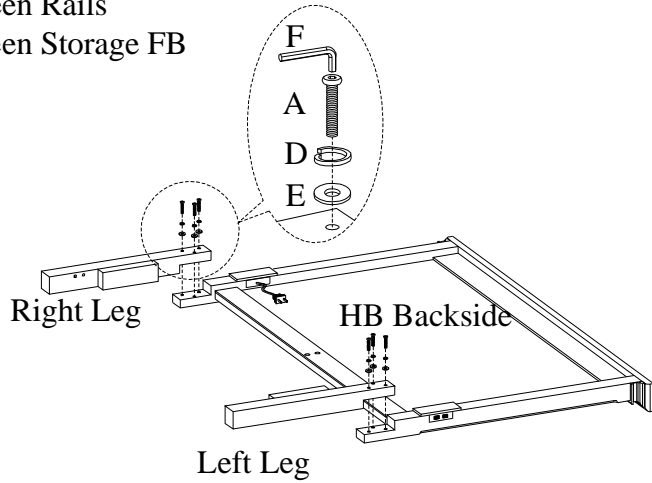

STEP 2: Attach the wood stretcher to the legs by using 4 bolts(C), lock washers(D) and flat washers(E).

STEP 3: Attach the center support leg to headboard and wood stretcher by using 3 bolts(B), lock washers(D) and flat washers(E).

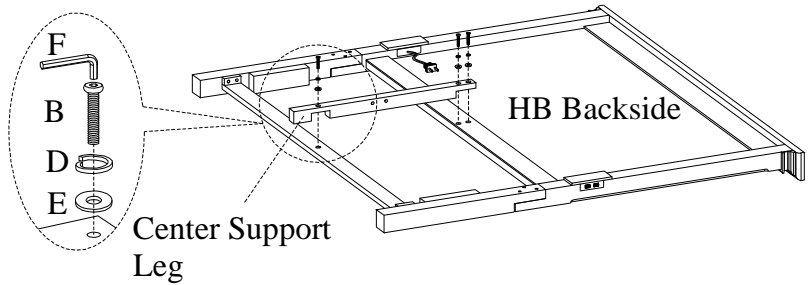

STEP 4: Put footboard upside down on a padded, clean surface. Attach support legs (for pedestal) and bun feet to footboard. Turn footboard right side up.

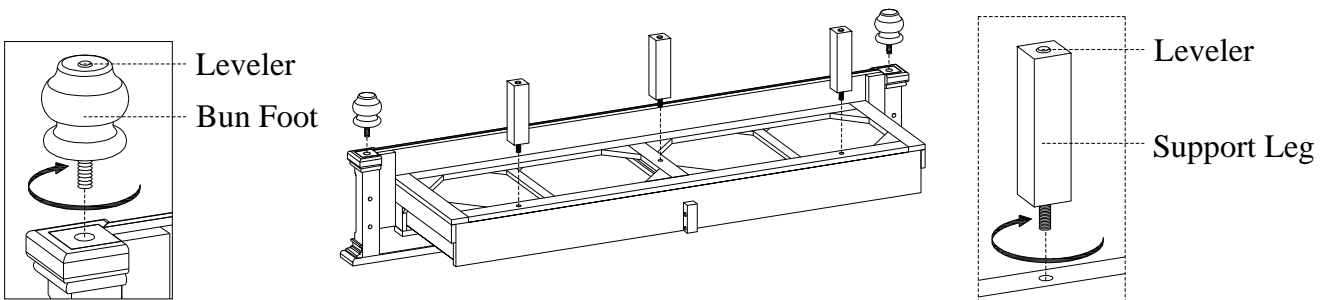



ITEM NO: I07-412-WBR/PEP/BLK Queen Panel HB
 I07-400-WBR/PEP/BLK Queen Sleigh HB
 I07-402-WBR/PEP/BLK Queen Rails
 I07-403D-WBR/PEP/BLK Queen Storage FB

STEP 8: Attach 2 support legs (for center rail) to the center rail using 4 bolts(T), lock washers(U) and flat washers(V). Use the Allen Wrench (W) to tighten all of the bolts.

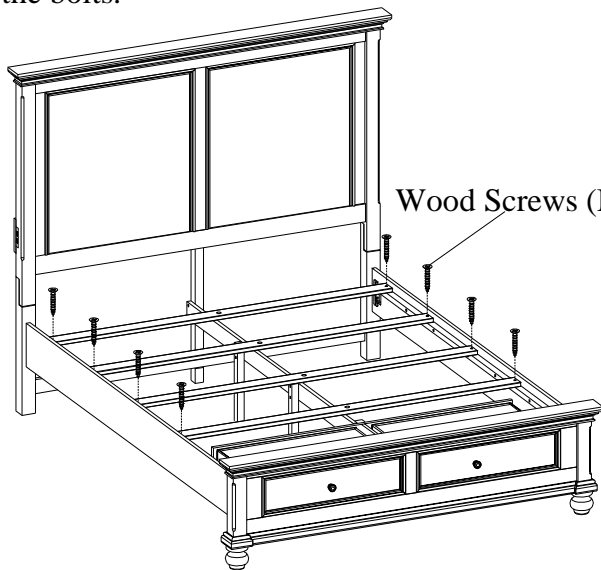
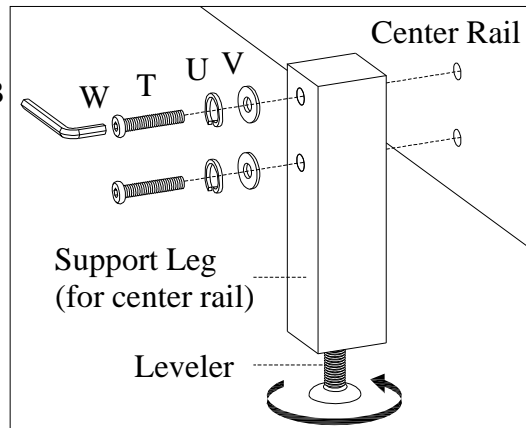

Wood Screws (M)

STEP 9: Arrange slats on the slat bearers and then lay decking on top of the slats. Make sure the slats are positioned along the seams of the decking as shown in the detail in STEP 9 under the pre-drilled hole. Remove the decking and attach slats to the slat bearers with wood screws (M).

STEP 10: Put the decking over the slats, secure decking to the slats with wood screws (S) through the pre-drilled holes in the decking as shown below.

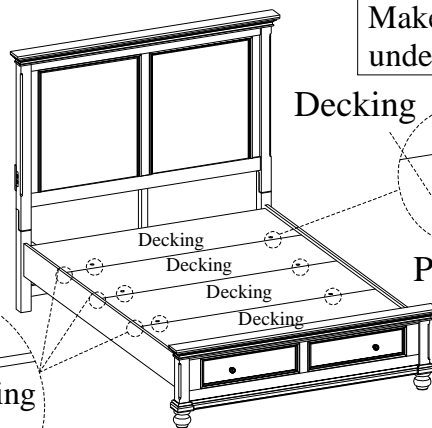

Make sure that there is a slat under the pre-drilled hole.

The slat should support both pieces of decking.

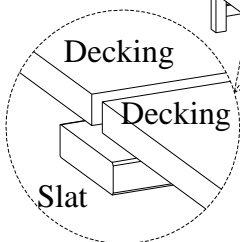

OPTION 2: Queen Storage Sleigh Bed

STEP 1: Put the headboard face down on a soft surface. Insert 8 wood dowels (G) into headboard, Then attach the left leg and right leg to headboard by using 6 bolts(H), lock washers(J) and flat washers(K).

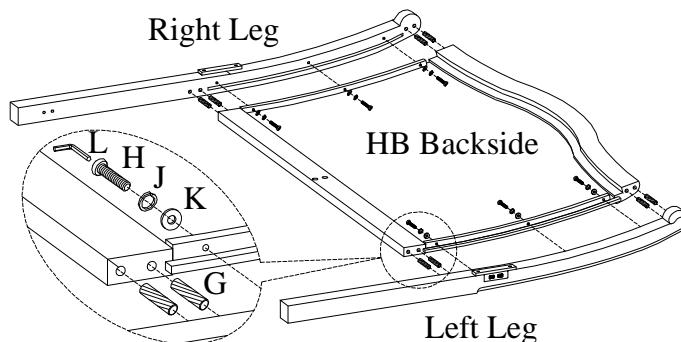



- ITEM NO: I07-412-WBR/PEP/BLK Queen Panel HB
- I07-400-WBR/PEP/BLK Queen Sleigh HB
- I07-402-WBR/PEP/BLK Queen Rails
- I07-403D-WBR/PEP/BLK Queen Storage FB

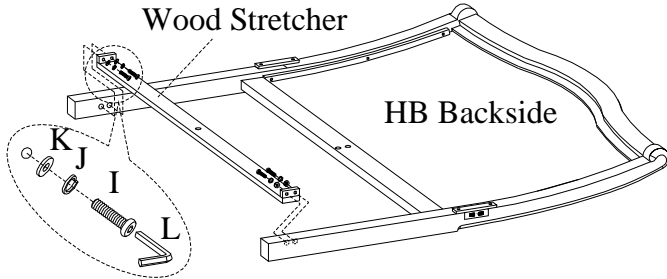

STEP 2: Attach the wood stretcher to the legs by using 4 bolts(I), lock washers(J) and flat washers(K).

STEP 3: Attach the center support leg to headboard and wood stretcher by using 3 bolts(H), lock washers(J) and flat washers(K).

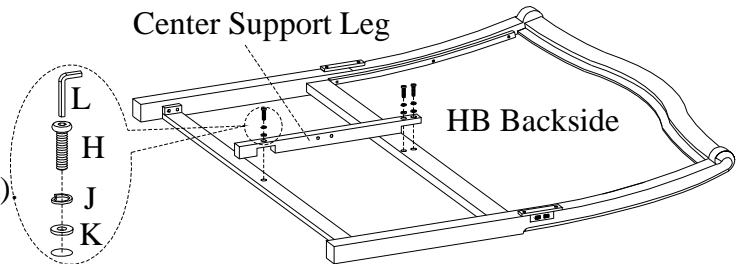

STEP 4 to STEP 11 are same as OPTION 1

FUNCTIONALITY INSTRUCTION

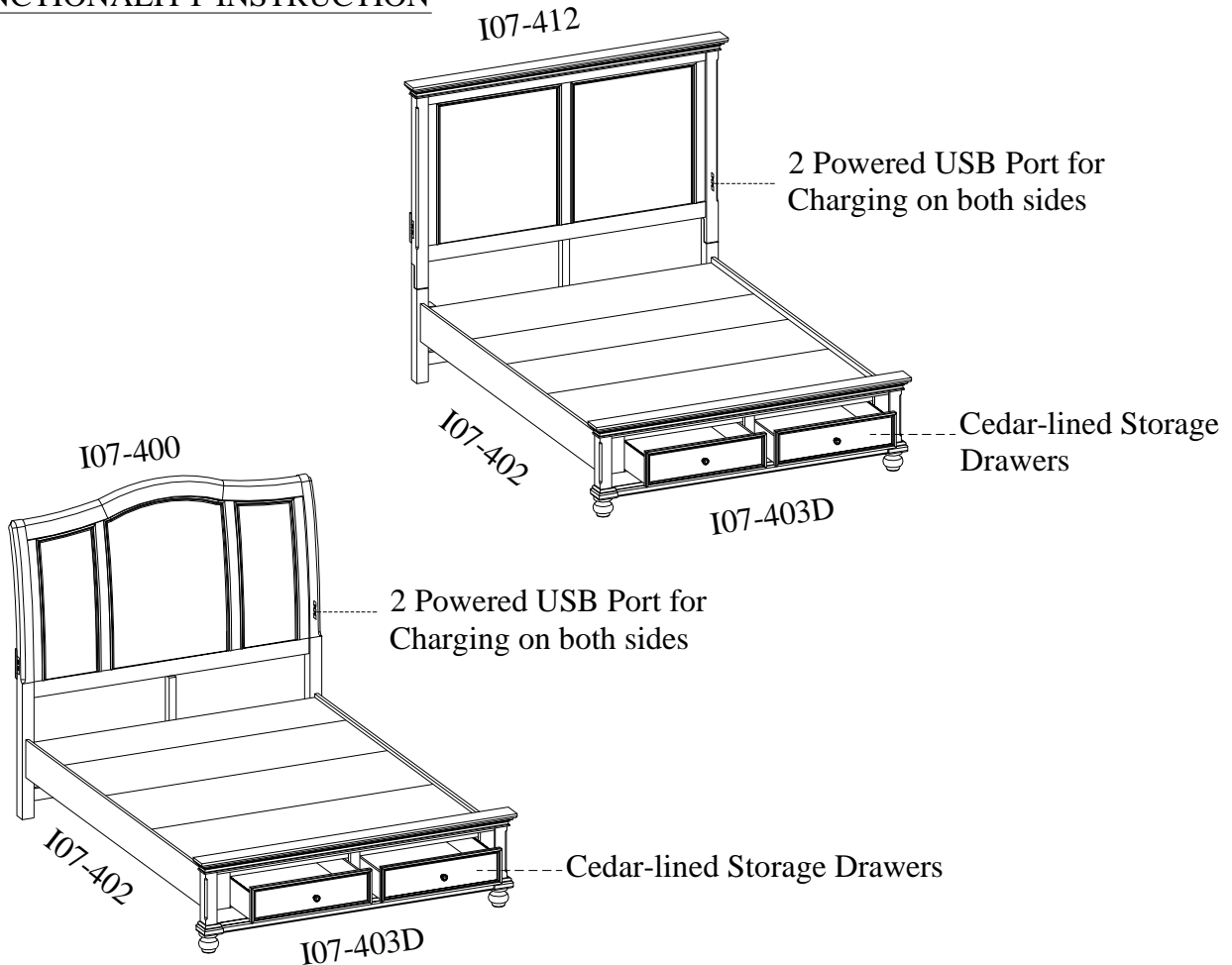



ITEM NO: I07-415-WBR/PEP/BLK	King Panel HB
I07-404-WBR/PEP/BLK	King Sleigh HB
I07-406-WBR/PEP/BLK	King Rails
I07-410-WBR/PEP/BLK	Cal King Rails
I07-407-WBR/PEP/BLK	King Low Profile FB

Thank you for purchasing this quality product. Be sure to check all packing material carefully for small parts that may come loose inside the carton during shipment.



UNIT SHOULD BE INSTALLED BY 2 OR MORE PERSONS.

OPTION 1: King/Cal King LP Panel Bed

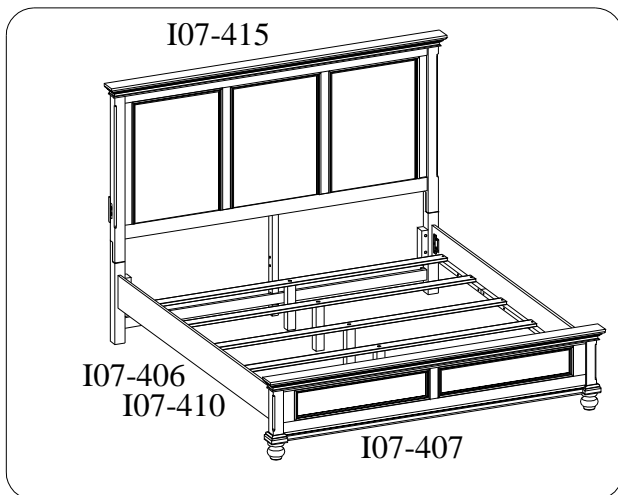

All Beds need to be set up in the exact final location so that after full assembly it will not need to be moved. Moving the bed will cause the support legs to move out of perpendicular (90 degree), weaken the support system, and may allow the bed to collapse.

OPTION 2: King/Cal King LP Sleigh Bed

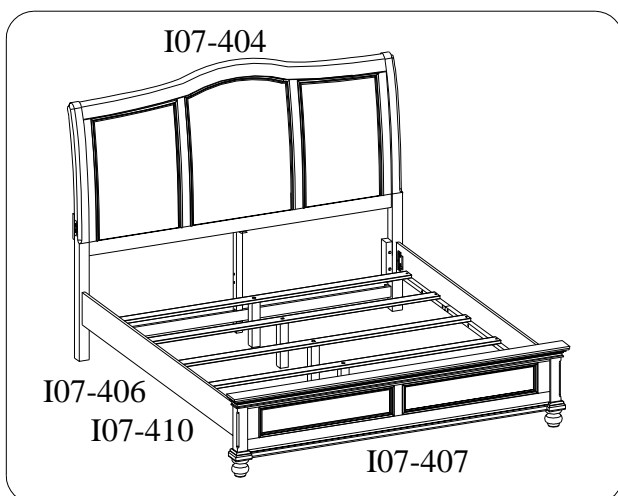

BEFORE USING THIS PRODUCT PLEASE READ, UNDERSTAND, AND FOLLOW THESE INSTRUCTIONS.
Save these instructions for future reference.

FOR INDOOR USE ONLY



ITEM NO: I07-415-WBR/PEP/BLK King Panel HB
 I07-404-WBR/PEP/BLK King Sleigh HB
 I07-406-WBR/PEP/BLK King Rails
 I07-410-WBR/PEP/BLK Cal King Rails
 I07-407-WBR/PEP/BLK King Low Profile FB

TOOLS REQUIRED (NOT PROVIDED)

PHILLIPS SCREWDRIVER

UTILITY KNIFE (FOR CAL KING)

HARDWARE LIST: I07-415

No.	Description	Sketch	Quantity
A	Bolt Ø5/16"*2"		6 PCS
B	Bolt Ø5/16"*1-9/16"		3 PCS
C	Bolt Ø5/16"*1-3/8"		4 PCS
D	Lock Washer Ø5/16"		13 PCS
E	Flat Washer Ø5/16" *3/4"		13 PCS
F	Allen Wrench 5mm		1 PC

HARDWARE LIST: I07-404

No.	Description	Sketch	Quantity
G	Wood Dowel Ø3/8"*1-9/16"		8 PCS
H	Bolt Ø5/16"*1-9/16"		9 PCS
I	Bolt Ø5/16"*1-3/8"		4 PCS
J	Lock Washer Ø5/16"		13 PCS
K	Flat Washer Ø5/16" *3/4"		13 PCS
L	Allen Wrench 5mm		1 PC

HARDWARE LIST: I07-406/410

No.	Description	Sketch	Quantity
M	Wood Screw M4*1-3/16"		10 PCS
N	Hanger Bolt Ø5/16"*3-1/16"		8 PCS
O	Lock Washer Ø5/16"		8 PCS
P	Flat washer 5/16 x 5/8"		8 PCS
Q	Hex Nut Ø5/16"		8 PCS
R	Hex Wrench 90*25*2mm		1 PC
S	Wood Cap (Only for 410)		8 PCS

COMPONENTS LIST: I07-415

No.	Description	Sketch	Quantity
1	Headboard		1 PC
2	Left Leg		1 PC
3	Right Leg		1 PC
4	Wood Stretcher		1 PC
5	Center Support Leg		1 PC

COMPONENTS LIST: I07-404

No.	Description	Sketch	Quantity
1	Headboard		1 PC
2	Left Leg		1 PC
3	Right Leg		1 PC
4	Wood Stretcher		1 PC
5	Center Support Leg		1 PC

COMPONENTS LIST: I07-406

No.	Description	Sketch	Quantity
1	Bed rails		2 PC
2	Slats		5 PC

COMPONENTS LIST: I07-410

No.	Description	Sketch	Quantity
1	Bed rails		2 PCS
2	Slats		5 PCS
3	Center rail		1 PC

COMPONENTS LIST: I07-407

No.	Description	Sketch	Quantity
1	Footboard		1 PC
2	Support leg (for slats)		5 PCS
3	Bun foot		2 PCS



ITEM NO: I07-415-WBR/PEP/BLK King Panel HB
 I07-404-WBR/PEP/BLK King Sleigh HB
 I07-406-WBR/PEP/BLK King Rails
 I07-410-WBR/PEP/BLK Cal King Rails
 I07-407-WBR/PEP/BLK King Low Profile FB

OPTION 1: King/Cal King LP Panel Bed

STEP 1: Put the headboard face down on a soft surface. Attach the left leg and right leg to headboard by using 6 bolts(A), lock washers(D) and flat washers(E).

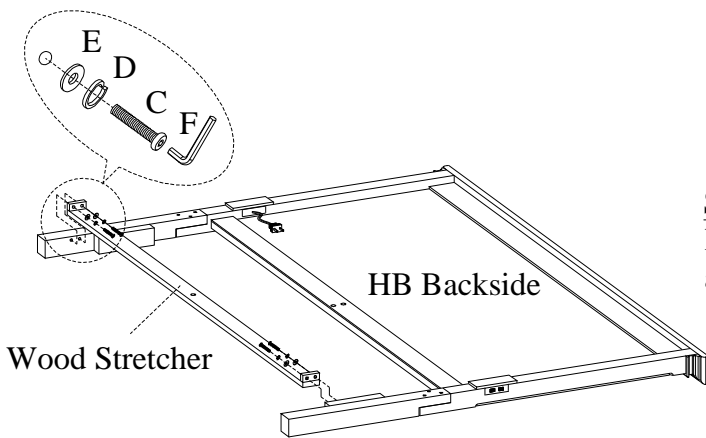
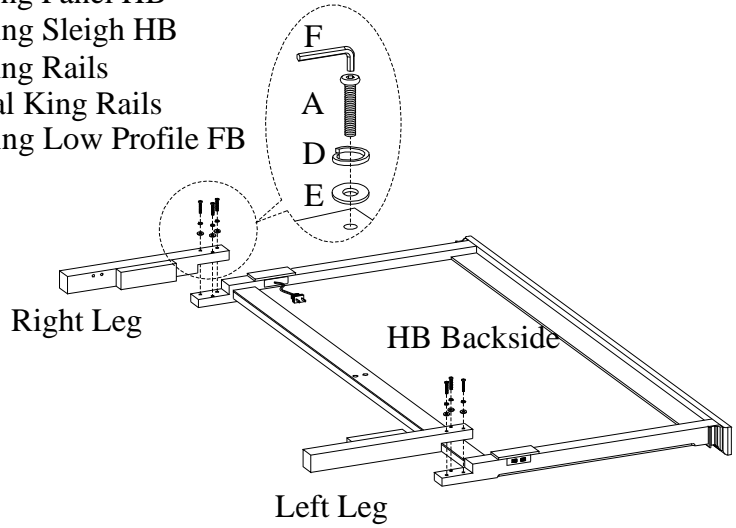

STEP 2: Attach the wood stretcher to the legs by using 4 bolts(C), lock washers(D) and flat washers(E).

STEP 3: Attach the center support leg to headboard and wood stretcher by using 3 bolts(B), lock washers(D) and flat washers(E).

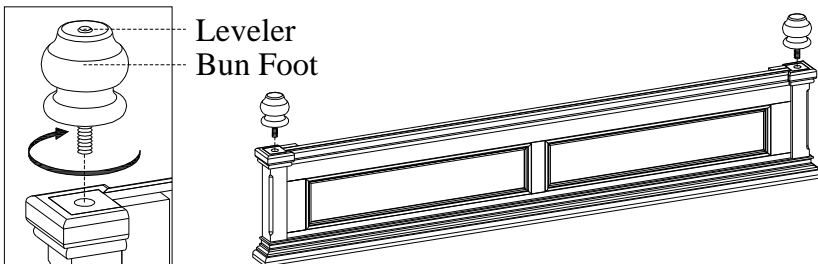
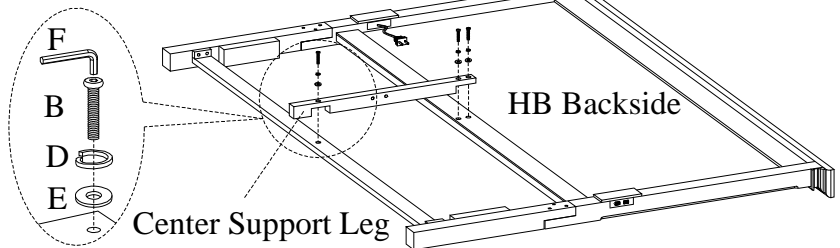

STEP 4: Put footboard upside down on a padded, clean surface. Attach bun feet to footboard. Turn footboard right side up.

STEP 5: The side rails may be used on either side. Arrange the side rails so the slat bearers are in LOWER POSITION prior to attachment in STEP 6.

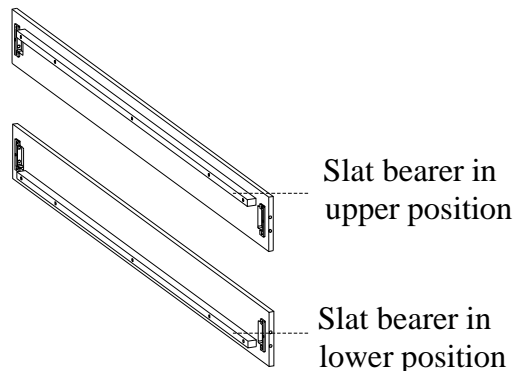



- | | |
|------------------------------|---------------------|
| ITEM NO: I07-415-WBR/PEP/BLK | King Panel HB |
| I07-404-WBR/PEP/BLK | King Sleigh HB |
| I07-406-WBR/PEP/BLK | King Rails |
| I07-410-WBR/PEP/BLK | Cal King Rails |
| I07-407-WBR/PEP/BLK | King Low Profile FB |

STEP 6: Screw the bolts(N) into HB & FB. Align the bolts with the holes in the end of side rails and attach the side rails to HB & FB using flat washer(P), lock washers(O) and nuts (Q). Then use a hex wrench(R) to tighten all the nuts.

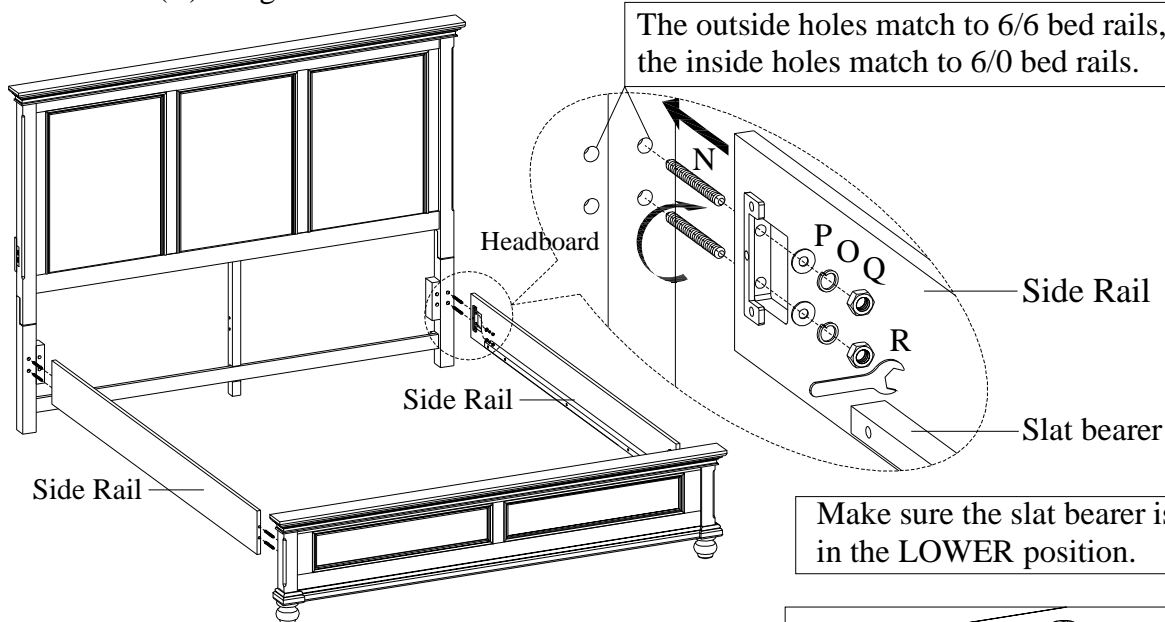

STEP 7: Attach the support legs with leveler to the slats. Adjust the levelers on bottom of support legs when necessary.

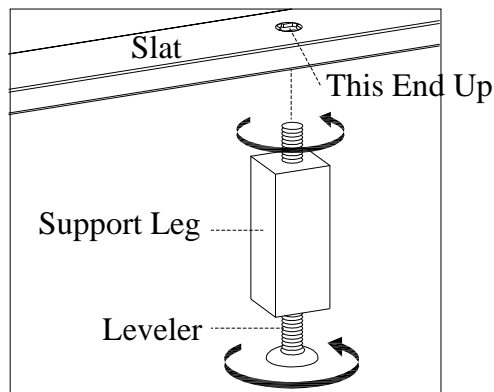
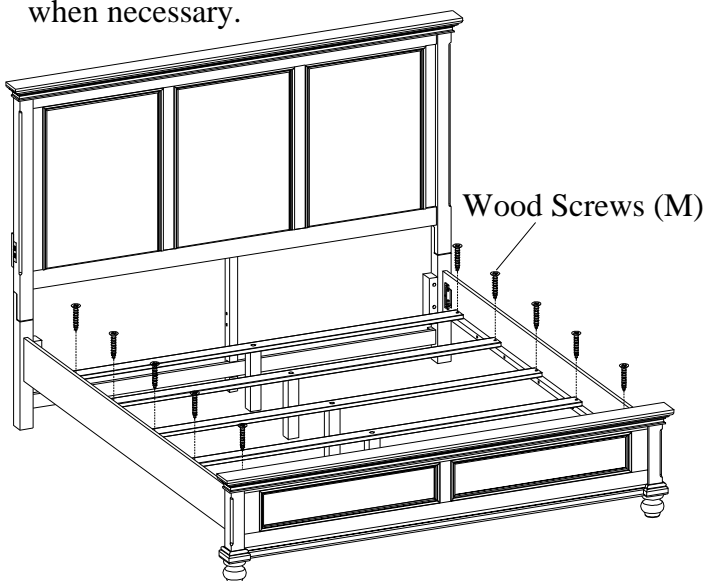

STEP 8: Arrange the slats on the slat bearer equally and attach to the slat bearer with wood screws (M).

STEP 9: For Cal King bed, insert wood caps(S) into the holes on headboard and footboard. For regular King bed, skip this step.

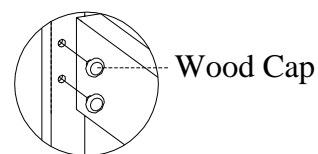



ITEM NO: I07-415-WBR/PEP/BLK King Panel HB
 I07-404-WBR/PEP/BLK King Sleigh HB
 I07-406-WBR/PEP/BLK King Rails
 I07-410-WBR/PEP/BLK Cal King Rails
 I07-407-WBR/PEP/BLK King Low Profile FB

OPTION 2: King/Cal King LP Sleigh Bed

STEP 1: Put the headboard face down on a soft surface. Insert 8 wood dowels (G) into headboard, Then attach the left leg and right leg to headboard by using 6 bolts(H), lock washers(J) and flat washers(K).

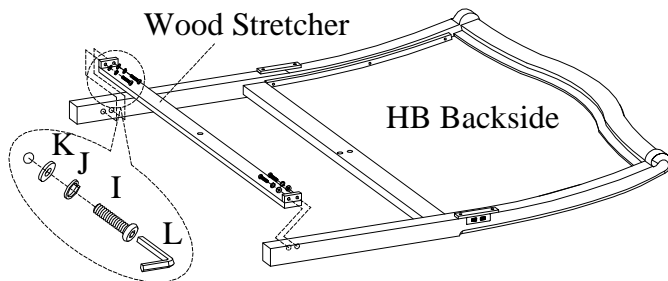
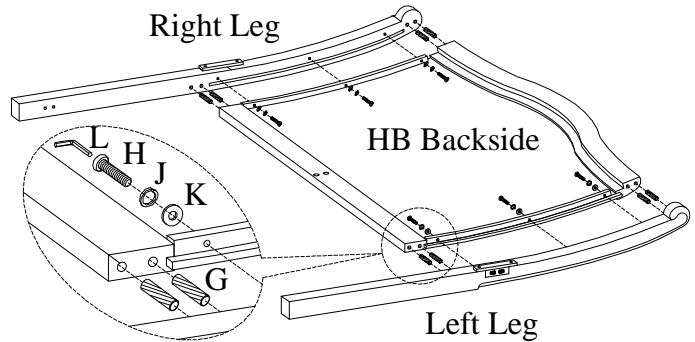

STEP 2: Attach the wood stretcher to the legs by using 4 bolts(I), lock washers(J) and flat washers(K).

STEP 3: Attach the center support leg to headboard and wood stretcher by using 3 bolts(H), lock washers(J) and flat washers(K).

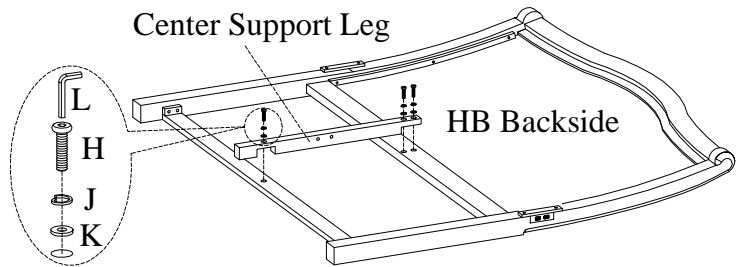

STEP 4 to STEP 11 are same as OPTION 1

FUNCTIONALITY INSTRUCTION

2 Powered USB Port for Charging on both sides

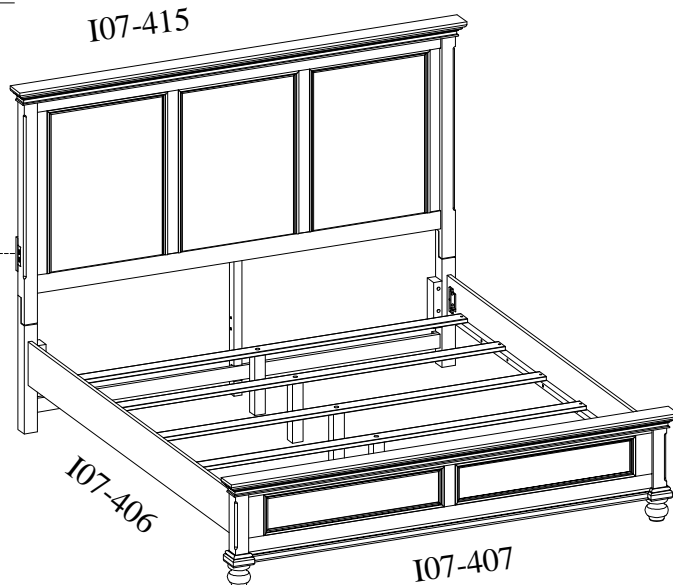



- ITEM NO: I07-415-WBR/PEP/BLK King Panel HB
 I07-404-WBR/PEP/BLK King Sleigh HB
 I07-406-WBR/PEP/BLK King Rails
 I07-410-WBR/PEP/BLK Cal King Rails
 I07-407-WBR/PEP/BLK King Low Profile FB

2 Powered USB Port for Charging on both sides

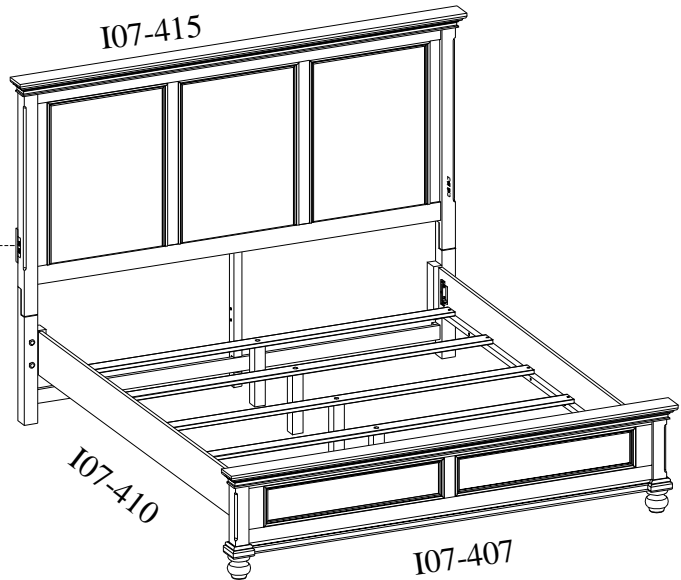

2 Powered USB Port for Charging on both sides

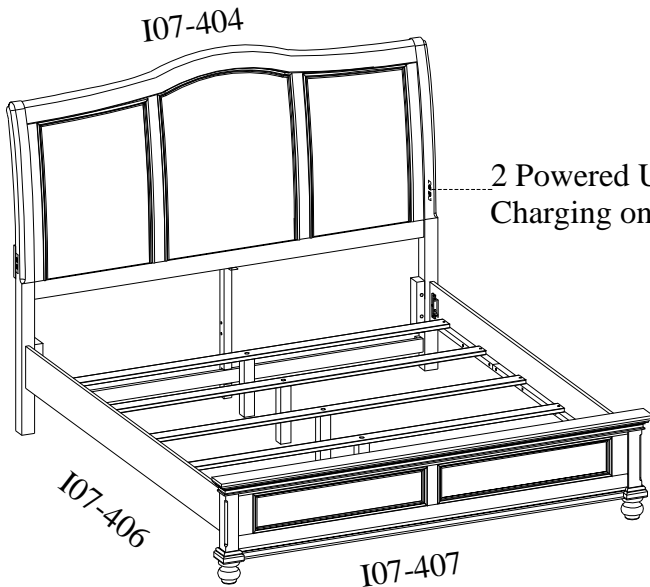

2 Powered USB Port for Charging on both sides

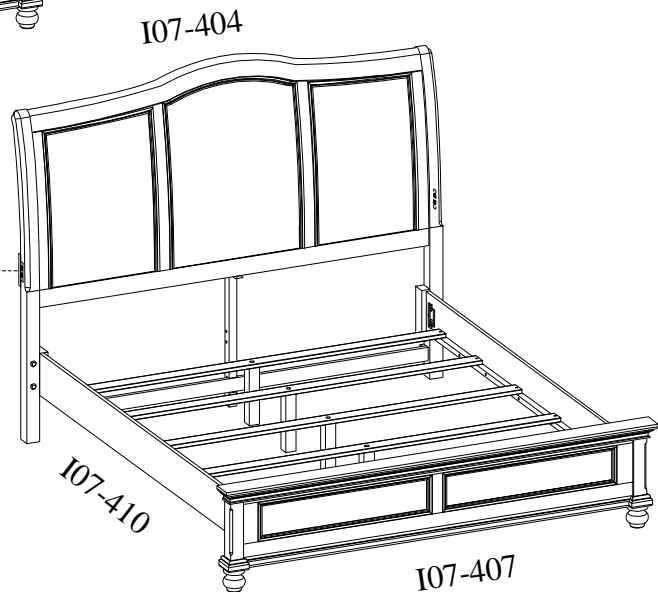



ITEM NO: I07-415-WBR/PEP/BLK King Panel HB
 I07-404-WBR/PEP/BLK King Sleigh HB
 I07-406-WBR/PEP/BLK King Rails
 I07-410-WBR/PEP/BLK Cal King Rails
 I07-407D-WBR/PEP/BLK King Storage FB

Thank you for purchasing this quality product. Be sure to check all packing material carefully for small parts that may come loose inside the carton during shipment.



UNIT SHOULD BE INSTALLED BY 2 OR MORE PERSONS.

OPTION 1: King/Cal King Storage Panel Bed

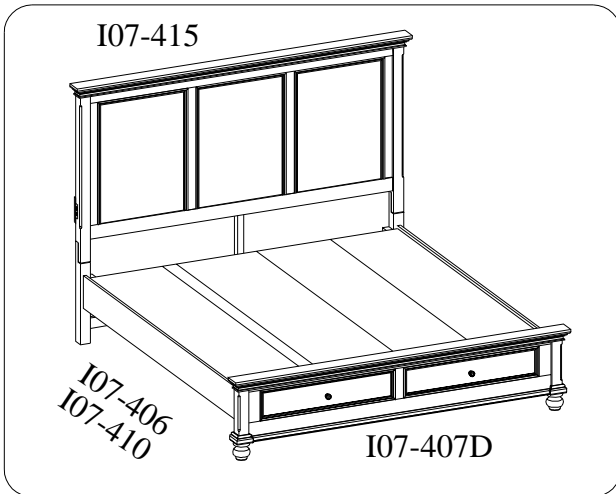

All Beds need to be set up in the exact final location so that after full assembly it will not need to be moved. Moving the bed will cause the support legs to move out of perpendicular (90 degree), weaken the support system, and may allow the bed to collapse.

OPTION 2: King/Cal king Storage Sleigh Bed

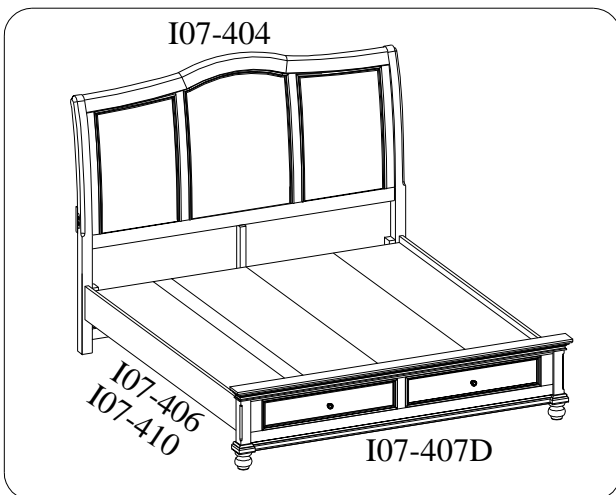

BEFORE USING THIS PRODUCT PLEASE READ, UNDERSTAND, AND FOLLOW THESE INSTRUCTIONS.
 Save these instructions for future reference.

FOR INDOOR USE ONLY



ITEM NO: I07-415-WBR/PEP/BLK King Panel HB
 I07-404-WBR/PEP/BLK King Sleigh HB
 I07-406-WBR/PEP/BLK King Rails
 I07-410-WBR/PEP/BLK Cal King Rails
 I07-407D-WBR/PEP/BLK King Storage FB

TOOLS REQUIRED (NOT PROVIDED)

PHILLIPS SCREWDRIVER

UTILITY KNIFE (FOR CAL KING)

HARDWARE LIST: I07-415

No.	Description	Sketch	Quantity
A	Bolt Ø5/16"*2"		6 PCS
B	Bolt Ø5/16"*1-9/16"		3 PCS
C	Bolt Ø5/16"*1-3/8"		4 PCS
D	Lock Washer Ø5/16"		13 PCS
E	Flat Washer Ø5/16" *3/4"		13 PCS
F	Allen Wrench 5mm		1 PC

HARDWARE LIST: I07-404

No.	Description	Sketch	Quantity
G	Wood Dowel Ø3/8"*1-9/16"		8 PCS
H	Bolt Ø5/16"*1-9/16"		9 PCS
I	Bolt Ø5/16"*1-3/8"		4 PCS
J	Lock Washer Ø5/16"		13 PCS
K	Flat Washer Ø5/16" *3/4"		13 PCS
L	Allen Wrench 5mm		1 PC

HARDWARE LIST: I07-406/410

No.	Description	Sketch	Quantity
M	Wood Screw M4*1-3/16"		10 PCS
N	Hanger Bolt Ø5/16"*3-1/16"		8 PCS
O	Lock Washer Ø5/16"		8 PCS
P	Flat washer 5/16 x 5/8"		8 PCS
Q	Hex Nut Ø5/16"		8 PCS
R	Hex Wrench 90*25*2mm		1 PC
S	Wood Cap (Only for 410)		8 PCS

HARDWARE LIST: I07-407D

No.	Description	Sketch	Quantity
T	Wood Screw M4*1		6 PCS
U	Bolt Ø5/16"*1-3/16"		8 PCS
V	Lock Washer Ø5/16"		8 PCS
W	Flat washer 5/16 x 3/4"		8 PCS
X	Allen Wrench 5mm		1 PC

COMPONENTS LIST: I07-415

No.	Description	Sketch	Quantity
1	Headboard		1 PC
2	Left Leg		1 PC
3	Right Leg		1 PC
4	Wood Stretcher		1 PC
5	Center Support Leg		1 PC

COMPONENTS LIST: I07-404

No.	Description	Sketch	Quantity
1	Headboard		1 PC
2	Left Leg		1 PC
3	Right Leg		1 PC
4	Wood Stretcher		1 PC
5	Center Support Leg		1 PC

COMPONENTS LIST: I07-406

No.	Description	Sketch	Quantity
1	Bed rails		2 PC
2	Slats		5 PC

COMPONENTS LIST: I07-410

No.	Description	Sketch	Quantity
1	Bed rails		2 PCS
2	Slats		5 PCS
3	Center rail (Long)		1 PC

COMPONENTS LIST: I07-407D

No.	Description	Sketch	Quantity
1	Footboard		1 PC
2	Support Leg (for center rail)		2 PCS
3	Support leg (for pedestal)		3 PCS
4	Decking		4 PCS
5	Center rail (Short)		1 PCS
6	Filler		1 PCS
7	Bun foot		2 PCS



- | | |
|------------------------------|-----------------|
| ITEM NO: I07-415-WBR/PEP/BLK | King Panel HB |
| I07-404-WBR/PEP/BLK | King Sleigh HB |
| I07-406-WBR/PEP/BLK | King Rails |
| I07-410-WBR/PEP/BLK | Cal King Rails |
| I07-407D-WBR/PEP/BLK | King Storage FB |

OPTION 1: King/Cal King Storage Panel Bed

STEP 1: Put the headboard face down on a soft surface. Attach the left leg and right leg to headboard by using 6 bolts(A), lock washers(D) and flat washers(E).

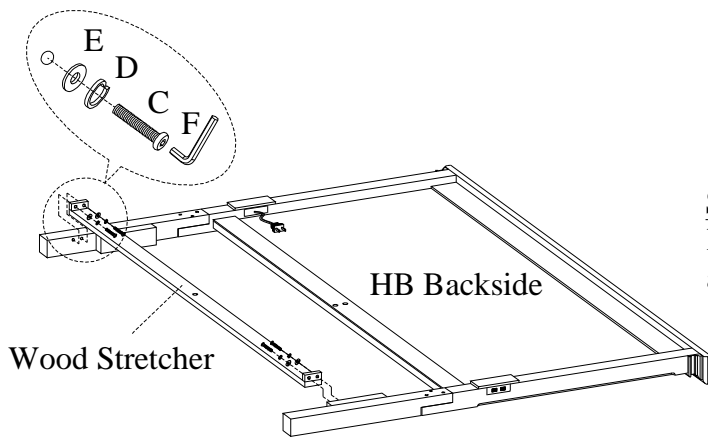
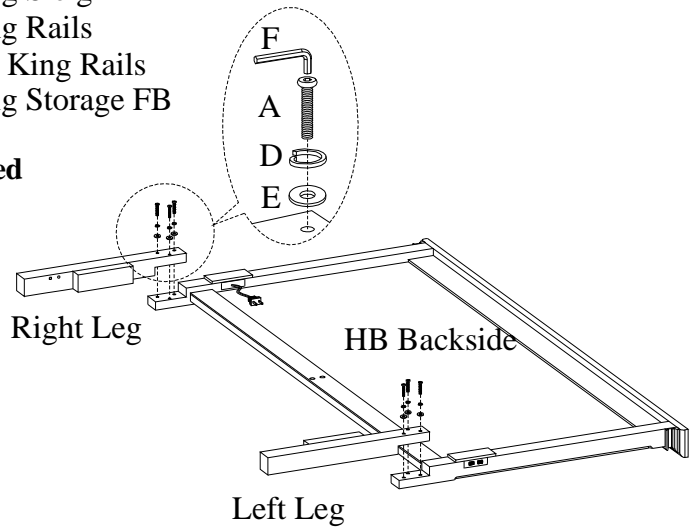

STEP 2: Attach the wood stretcher to the legs by using 4 bolts(C), lock washers(D) and flat washers(E).

STEP 3: Attach the center support leg to headboard and wood stretcher by using 3 bolts(B), lock washers(D) and flat washers(E).

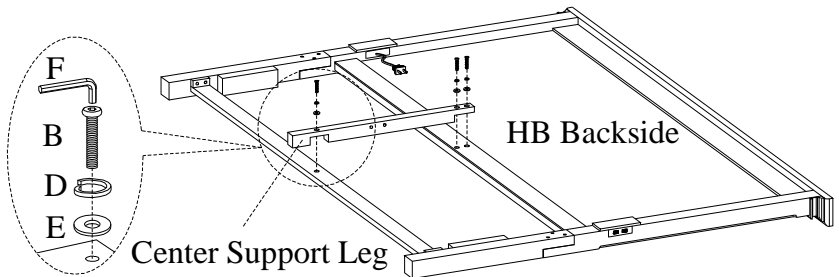

STEP 4: Put footboard upside down on a padded, clean surface. Attach support legs (for pedestal) and bun feet to footboard. Turn footboard right side up.

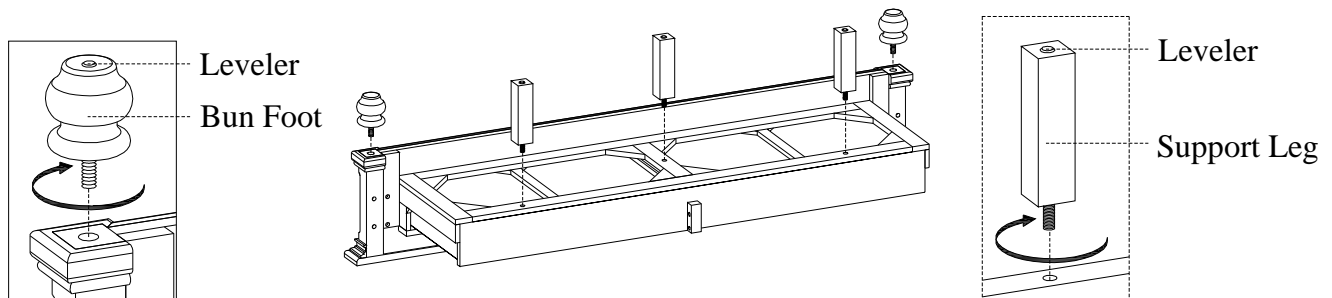



- ITEM NO: I07-415-WBR/PEP/BLK King Panel HB
- I07-404-WBR/PEP/BLK King Sleigh HB
- I07-406-WBR/PEP/BLK King Rails
- I07-410-WBR/PEP/BLK Cal King Rails
- I07-407D-WBR/PEP/BLK King Storage FB

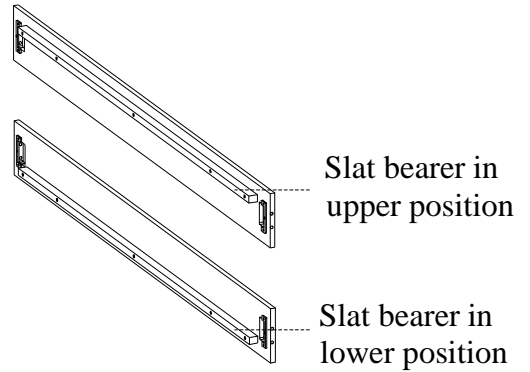

STEP 5: The side rails may be used on either side. Arrange the side rails so the slat bearers are in UPPER POSITION prior to attachment in STEP 6.

STEP 6: Screw the bolts(N) into HB & FB. Align the bolts with the holes in the end of side rails and attach the side rails to HB & FB using flat washer(P), lock washers(O) and nuts (Q). Then use a hex wrench(R) to tighten all the nuts.

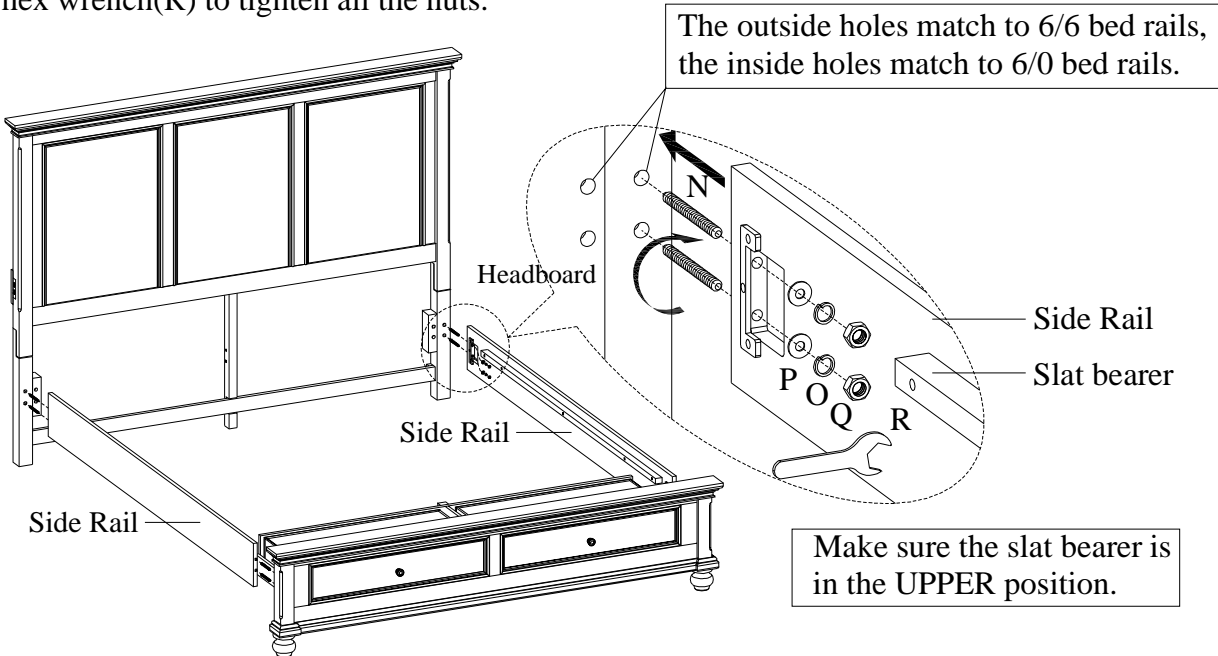

STEP 7: Attach center rail to the footboard and center support leg of headboard using 4 bolts(U), lock washers(V) and flat washers(W).

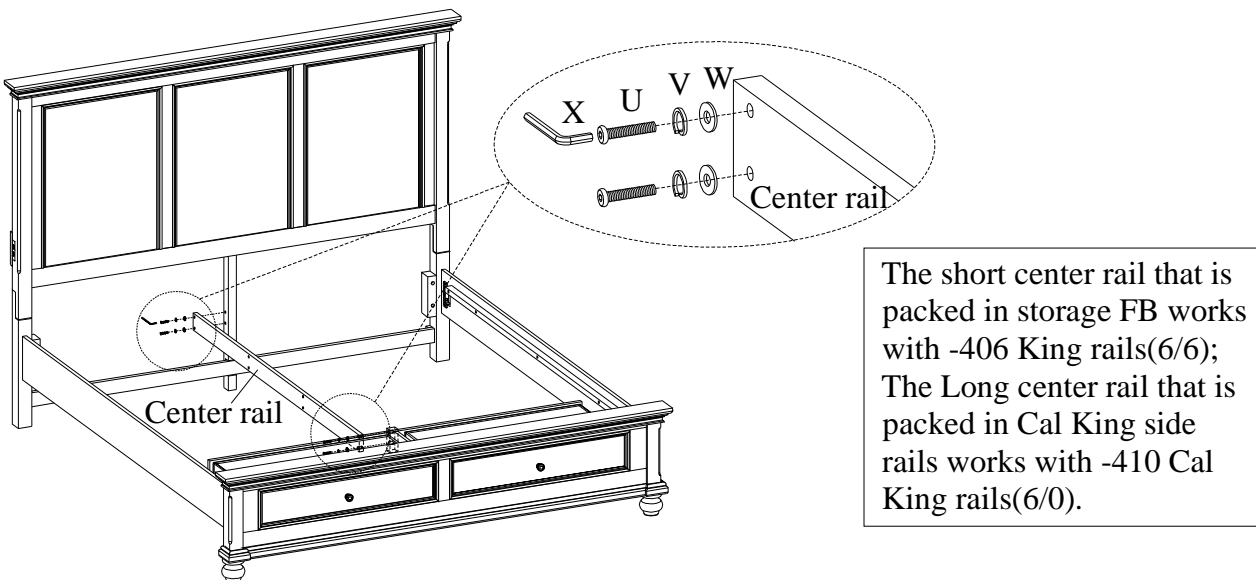



ITEM NO: I07-415-WBR/PEP/BLK King Panel HB
 I07-404-WBR/PEP/BLK King Sleigh HB
 I07-406-WBR/PEP/BLK King Rails
 I07-410-WBR/PEP/BLK Cal King Rails
 I07-407D-WBR/PEP/BLK King Storage FB

STEP 8: Attach 2 support legs (for center rail) to the center rail using 4 bolts(U), lock washers(V) and flat washers(W). Use the Allen Wrench (X) to tighten all of the bolts.

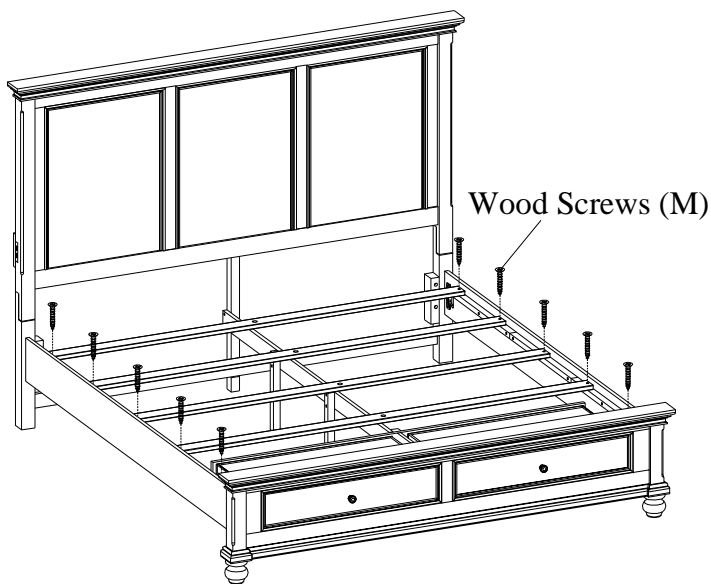
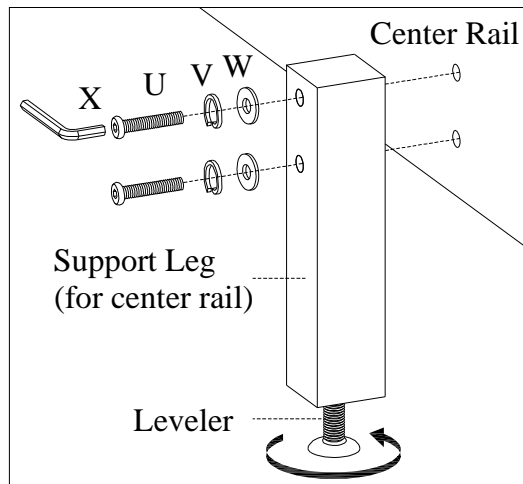

STEP 9: Arrange slats on the slat bearers and then lay the decking on top of the slats. Make sure the top and bottom slats are situated underneath the pre-drilled holes as shown below in STEP 11. Remove the decking and attach slats to the slat bearers with wood screws (M).

STEP 10: For Cal King bed, use a utility knife to cut off the small piece at the notch and discard. For regular King bed, skip this step.

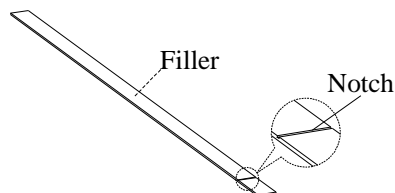

STEP 11: Put the decking over the slats, secure decking to the slats with wood screws (T) through the pre-drilled holes in the decking as shown below.

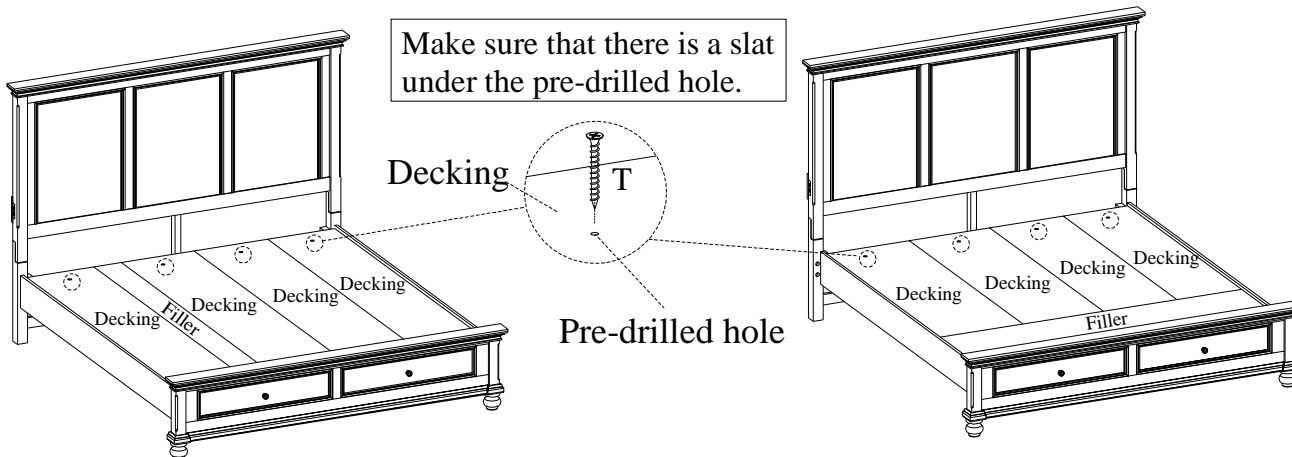

STEP 12: For Cal King bed, insert wood caps(S) into the holes on headboard and footboard. For regular King bed, skip this step.

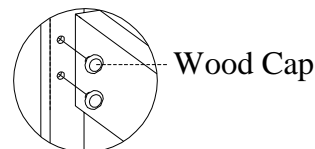



ITEM NO: I07-415-WBR/PEP/BLK King Panel HB
 I07-404-WBR/PEP/BLK King Sleigh HB
 I07-406-WBR/PEP/BLK King Rails
 I07-410-WBR/PEP/BLK Cal King Rails
 I07-407D-WBR/PEP/BLK King Storage FB

OPTION 2: King/Cal king Storage Sleigh Bed

STEP 1: Put the headboard face down on a soft surface. Insert 8 wood dowels (G) into headboard, Then attach the left leg and right leg to headboard by using 6 bolts(H), lock washers(J) and flat washers(K).

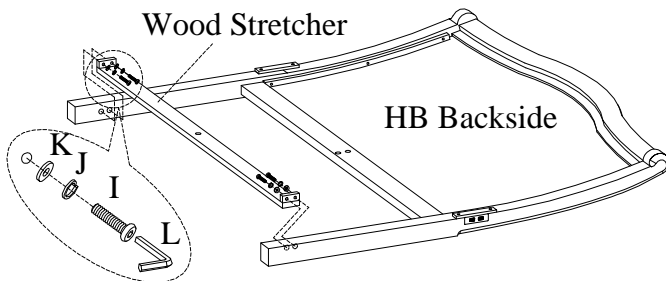
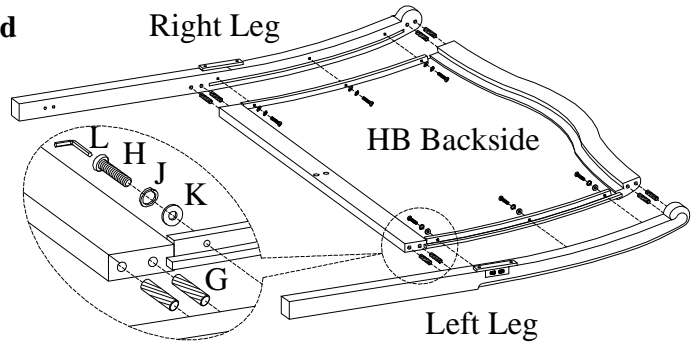

STEP 2: Attach the wood stretcher to the legs by using 4 bolts(I), lock washers(J) and flat washers(K).

STEP 3: Attach the center support leg to headboard and wood stretcher by using 3 bolts(H), lock washers(J) and flat washers(K).

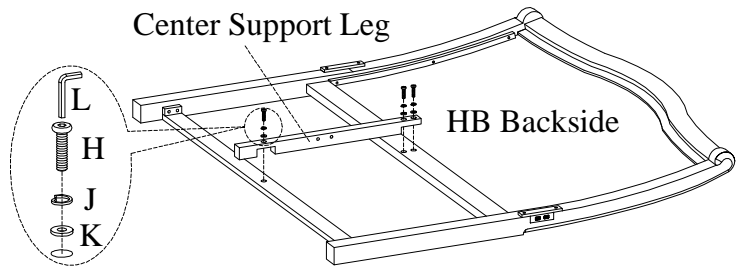

STEP 4 to STEP 11 are same as OPTION 1

FUNCTIONALITY INSTRUCTION

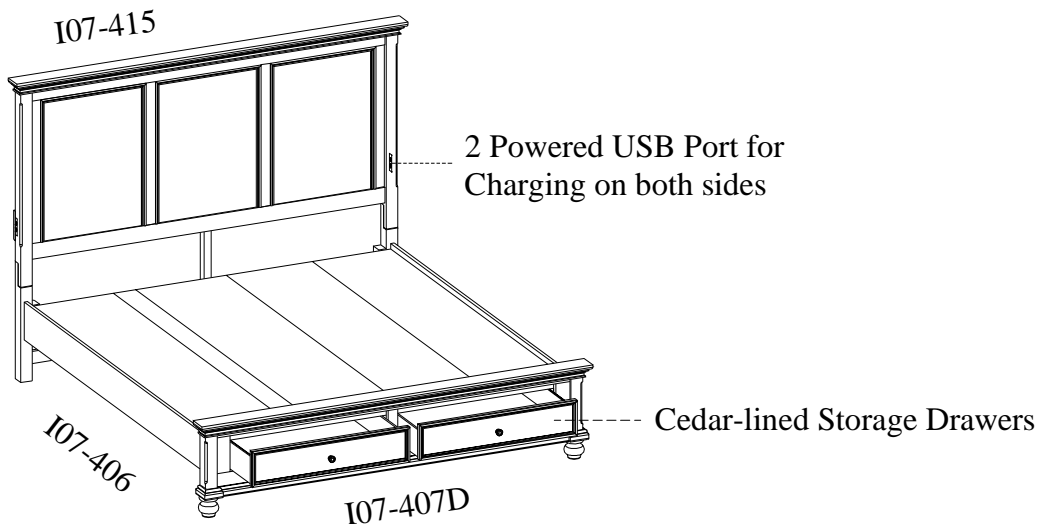



- ITEM NO: I07-415-WBR/PEP/BLK King Panel HB
 I07-404-WBR/PEP/BLK King Sleigh HB
 I07-406-WBR/PEP/BLK King Rails
 I07-410-WBR/PEP/BLK Cal King Rails
 I07-407D-WBR/PEP/BLK King Storage FB

