

ITEM NO: I248-6050S Counter Height Chair w/ Wood Seat (2/Ctn)

Thank you for purchasing this quality product. Be sure to check all packing material carefully for small parts that may come loose inside the carton during shipment.

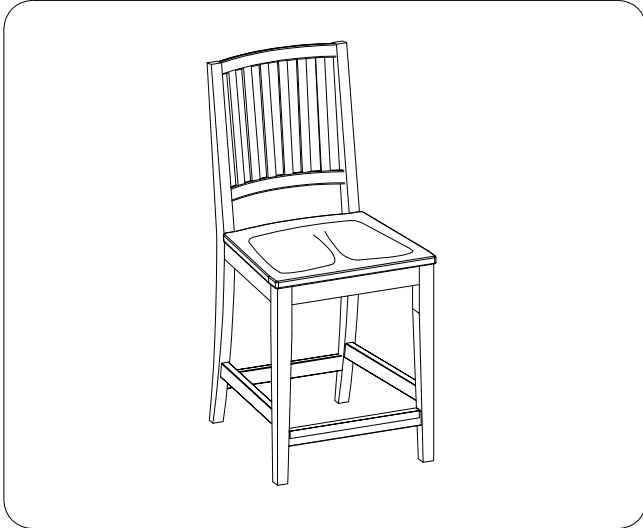

TOOLS REQUIRED (NOT PROVIDED)
PHILLIPS SCREWDRIVER

HARDWARE LIST:			
No.	Description	Sketch	Quantity
A	Bolt Ø5/16" x 3-1/4"		4 PCS
B	Bolt Ø5/16" x 2-1/4"		4 PCS
C	Bolt Ø5/16" x 1-1/2"		2 PCS
D	Lock Washer Ø5/16"		10 PCS
E	Flat Washer Ø5/16" x 3/4"		10 PCS
F	Allen Wrench 4mm		1 PC
G	Wood Screw #8 x 1-1/2"		6 PCS

COMPONENTS LIST:			
No.	Description	Sketch	Quantity
1	Chair Back		1 PC
2	Chair Seat		1 PC
3	Front Leg (Left)		1 PC
4	Front Leg (Right)		1 PC
5	Front Stretcher		1 PC
6	Side Stretcher (Left)		1 PC
7	Side Stretcher (Right)		1 PC

FUNCTIONALITY INSTRUCTION

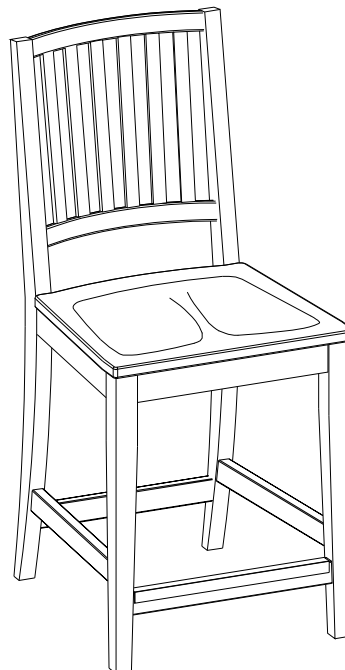

BEFORE USING THIS PRODUCT PLEASE READ, UNDERSTAND, AND FOLLOW THESE INSTRUCTIONS. Save these instructions for future reference.

FOR INDOOR USE ONLY

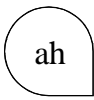

ITEM NO: I248-6050S

Counter Height Chair w/ Wood Seat (2/Ctn)

STEP 1: Assemble the front leg(right) and the front leg(left) with front stretcher using screws(G). Making sure the drill holes on each front leg and the chamfers on all legs are aligned as shown right.

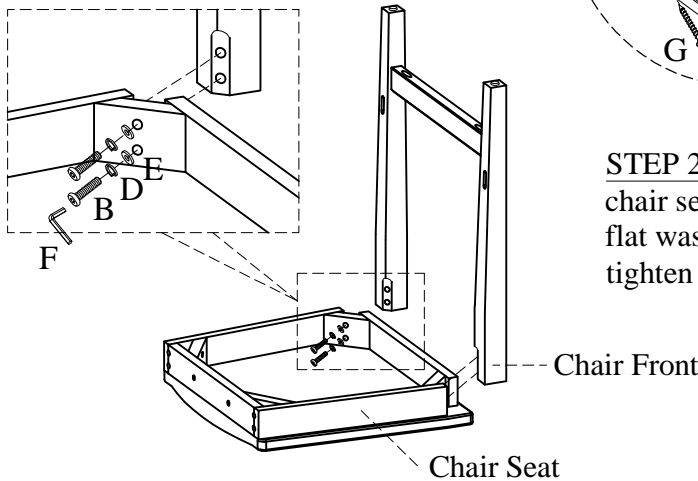
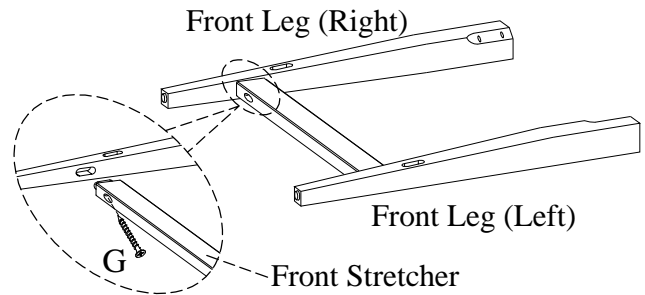

STEP 2: Attach the assembled chair front to chair seat by using 4 bolts(B), lock washers(D), flat washers(E) with an allen wrench(F), Do not tighten bolts until STEP 4.

STEP 3: Attach the chair seat to chair back by using 4 bolts(A), 2 bolts(C), lock washers(D), flat washers(E) with an allen wrench(F), Do not completely tighten bolts.

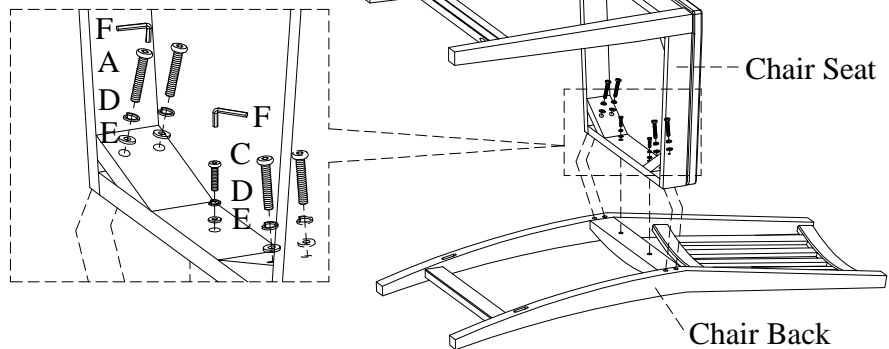

Side Stretcher (Right)

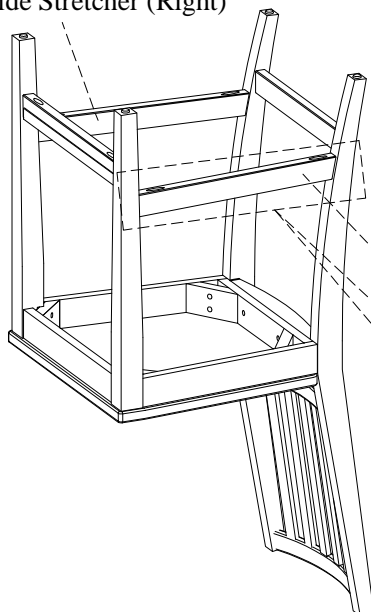

Side Stretcher (Left)

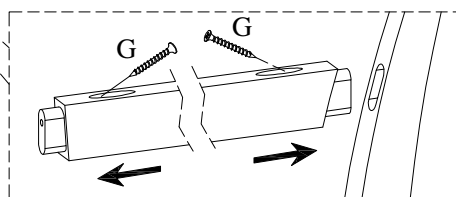

STEP 4: Attach the side stretcher(left) and side stretcher(right) to the front legs and chair back using wood screws(G). Completely tighten all wood screws and bolts. Turn the assembled chair to the upright position.

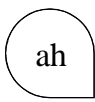

ITEM NO: I248-6052 Counter Height Din Table

Thank you for purchasing this quality product. Be sure to check all packing material carefully for small parts that may come loose inside the carton during shipment.

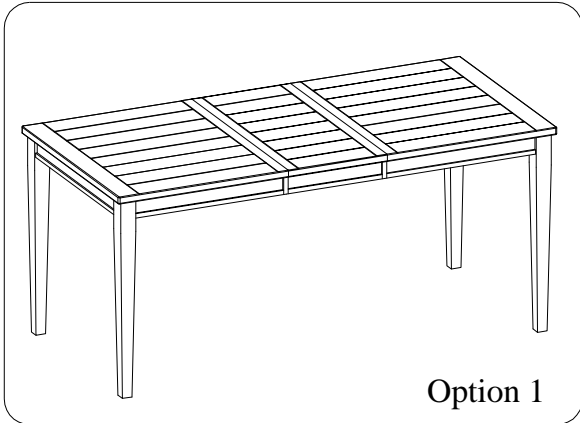



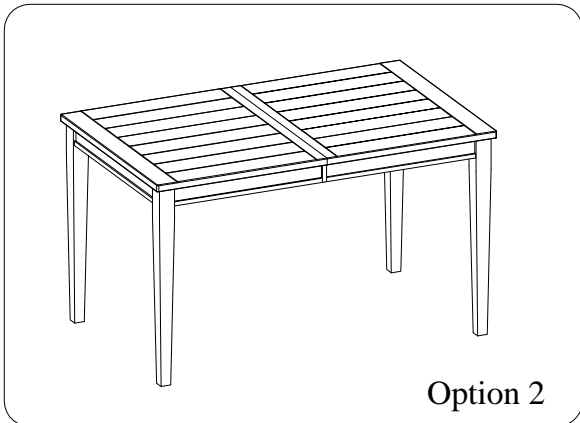



Option 1



Option 2

TOOLS REQUIRED (NOT PROVIDED)	
PHILLIPS SCREWDRIVER	

HARDWARE LIST:			
No.	Description	Sketch	Quantity
A	Bolt Ø5/16" x 2-1/4"		8 PCS
B	Lock Washer Ø5/16"		8 PCS
C	Flat Washer Ø5/16" x 3/4"		8 PCS
D	Allen Wrench 4mm		1 PC

COMPONENTS LIST:			
No.	Description	Sketch	Quantity
1	Table Top		1 PC
2	Leg		4 PCS

FUNCTIONALITY INSTRUCTION

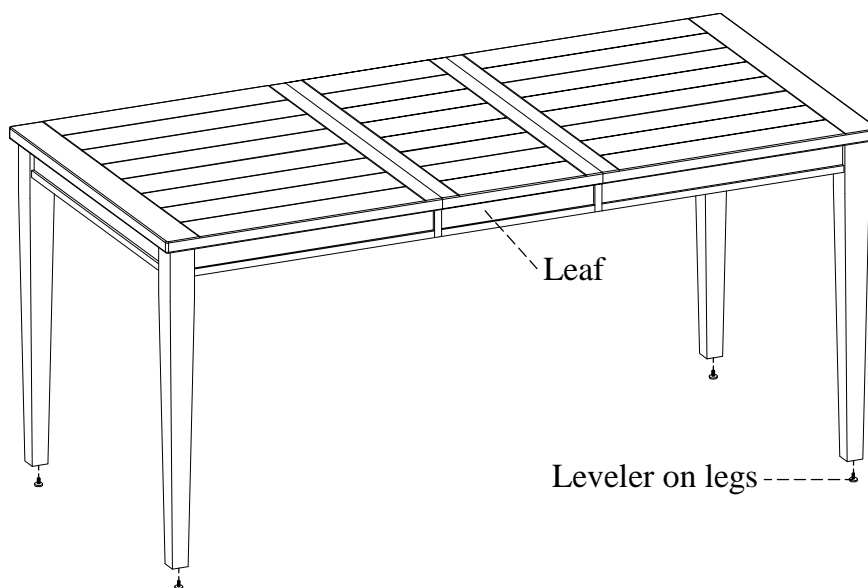

BEFORE USING THIS PRODUCT PLEASE READ, UNDERSTAND, AND FOLLOW THESE INSTRUCTIONS. Save these instructions for future reference.

FOR INDOOR USE ONLY

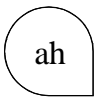

ITEM NO: I248-6052 Counter Height Din Table

For OPTION 1:

STEP 1: Lay the table top face down on a soft surface. Attach the legs to table top by using 8 bolts(A), lock washers(B), flat washers(C) with an allen wrench(D). Completely tighten all bolts. Remove 4 wood blocks by taking out 8 wood screws, then turn the assembled table to the upright position.

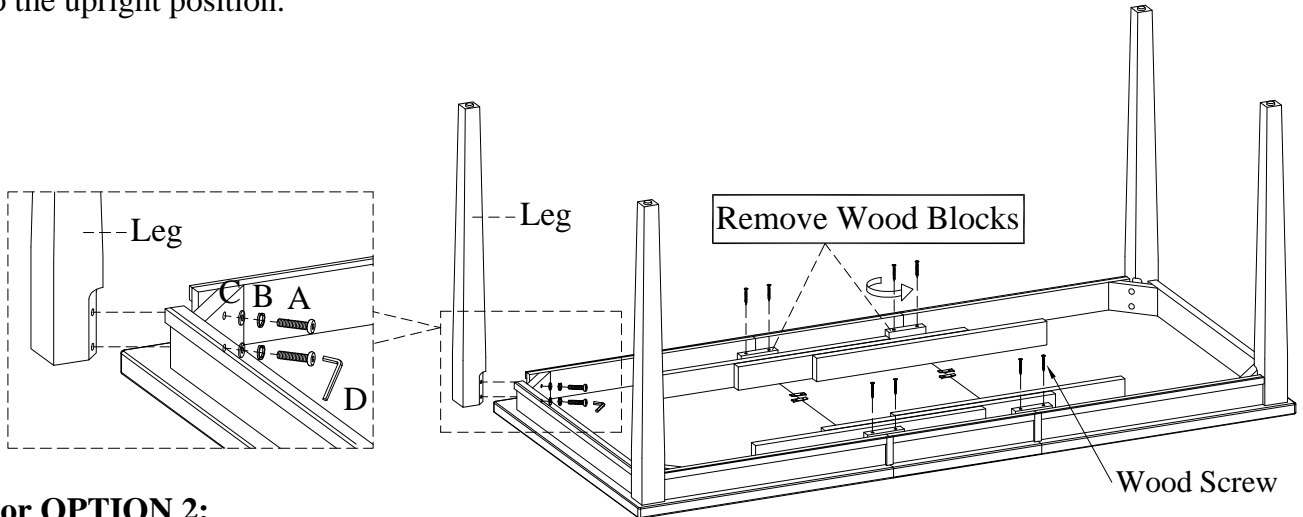

For OPTION 2:

STEP 2: Turn the table locks under the table top to the OFF position as shown below. Fully extend both sides of table as shown below.

STEP 3: Remove the leaf in opening and push ends of table together to close the gaps in table top. Turn the table locks to the ON position.

