

- ITEM NO: I3048-444P Q/K Bed Tall Posts  
 I3048-445P Q/K Bed Short Posts  
 I3048-406 King Rails  
 I3048-410 Cal King Rails  
 I3048-443 King HB & FB Panels

Thank you for purchasing this quality product. Be sure to check all packing material carefully for small parts that may come loose inside the carton during shipment.

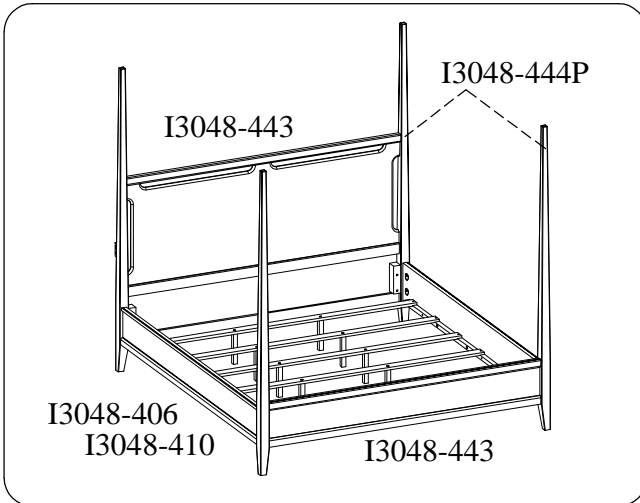

**UNIT SHOULD BE INSTALLED BY 2 OR MORE PERSONS.**



TOOLS REQUIRED (NOT PROVIDED)
PHILLIPS SCREWDRIVER

All Beds need to be set up in the exact final location so that after full assembly it will not need to be moved. Moving the bed will cause the support legs to move out of perpendicular (90 degree), weaken the support system, and may allow the bed to collapse.

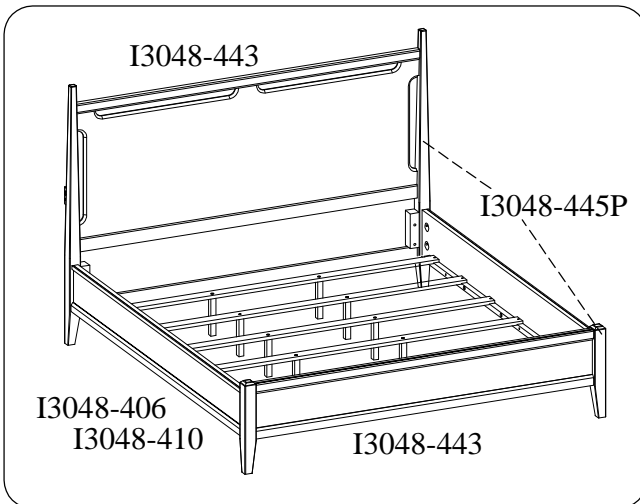

**WARNING!** Before using this product, please read, understand, and follow these instructions. Failure to follow each of these assembly instructions precisely may result in damage to the product and / or injury to the consumer.

FOR INDOOR USE ONLY



ITEM NO: I3048-444P Q/K Bed Tall Posts  
 I3048-445P Q/K Bed Short Posts  
 I3048-406 King Rails  
 I3048-410 Cal King Rails  
 I3048-443 King HB & FB Panels

### HARDWARE LIST: I3048-443

No.	Description	Sketch	Quantity
A	Bolt Ø5/16" x 1-1/2"		14 PCS
B	Lock Washer Ø5/16"		14 PCS
C	Flat Washer Ø5/16" x 5/8"		14 PCS
D	Allen Wrench M4		1 PC
E	Hanger Bolt Ø5/16" x 3"		6 PCS
F	Half Moon Washer Ø5/16"		6 PCS
G	Hex Nut Ø5/16"		6 PCS
H	Hex Wrench 13mm		1 PC

### HARDWARE LIST: I430-406/410

No.	Description	Sketch	Quantity
I	Hanger Bolt Ø5/16" x 3"		8 PCS
J	Half Moon Washer Ø5/16"		8 PCS
K	Hex Nut Ø5/16"		8 PCS
L	Hex Wrench 13mm		1 PC
M	Wood Screw #4 x 1-1/4"		12 PCS
N	Wood Cap (only for -410)		8 PCS

### COMPONENTS LIST: I3048-444P

No.	Description	Sketch	Quantity
1	HB Post-Left		1 PC
2	HB Post-Right		1 PC
3	FB Post-Left		1 PC
4	FB Post-Right		1 PC

### COMPONENTS LIST: I3048-445P

No.	Description	Sketch	Quantity
1	HB Post-Left		1 PC
2	HB Post-Right		1 PC
3	FB Post-Left		1 PC
4	FB Post-Right		1 PC

### COMPONENTS LIST: I3048-443

No.	Description	Sketch	Quantity
1	Headboard (HB)		1 PC
2	Footboard (FB)		1 PC
3	Wood Stretcher		1 PC
4	Support Leg		12 PCS

### COMPONENTS LIST: I3048-406

No.	Description	Sketch	Quantity
1	Bed rail		2 PCS
2	Slat		6 PCS

### COMPONENTS LIST: I3048-410

No.	Description	Sketch	Quantity
1	Bed rail		2 PCS
2	Slat		6 PCS



ITEM NO: I3048-444P	Q/K Bed Tall Posts
I3048-445P	Q/K Bed Short Posts
I3048-406	King Rails
I3048-410	Cal King Rails
I3048-443	King HB & FB Panels

**STEP 1:** Lay the HB posts - Left / Right face down on a soft surface. Attach the headboard (HB) and wood stretcher to HB posts - Left / Right by using 14 bolts (A), lock washers (B) and flat washers (C). Use the Allen wrench provided to tighten all the bolts.

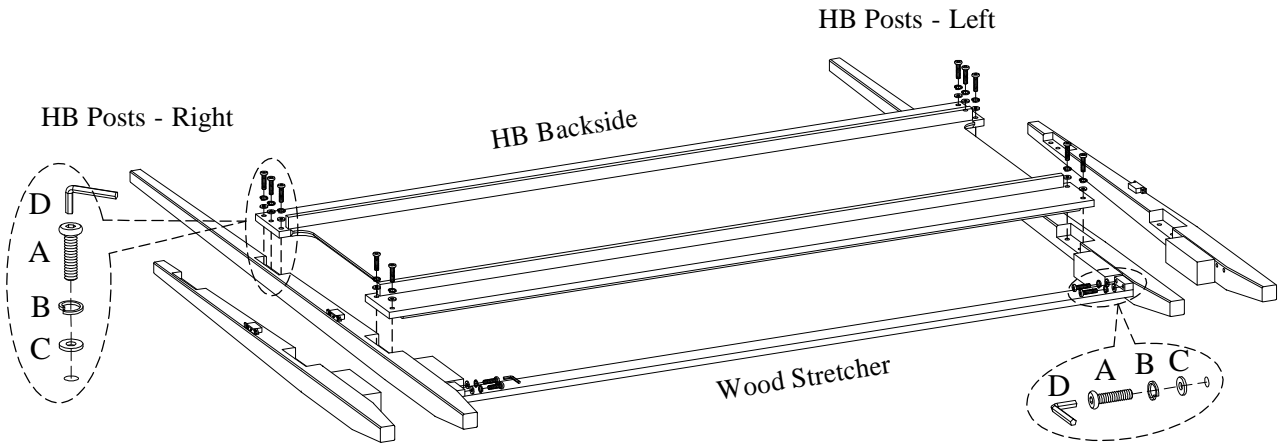

**STEP 2:** Lay the FB posts - Left / Right face down on a soft surface. Screw the bolts (E) into FB posts - left / right. Align the bolts with the holes in the end of footboard and attach the footboard to FB posts - left / right using half moon Washer (F) and hex nuts (G). Then use a hex wrench (H) to tighten all the nuts.

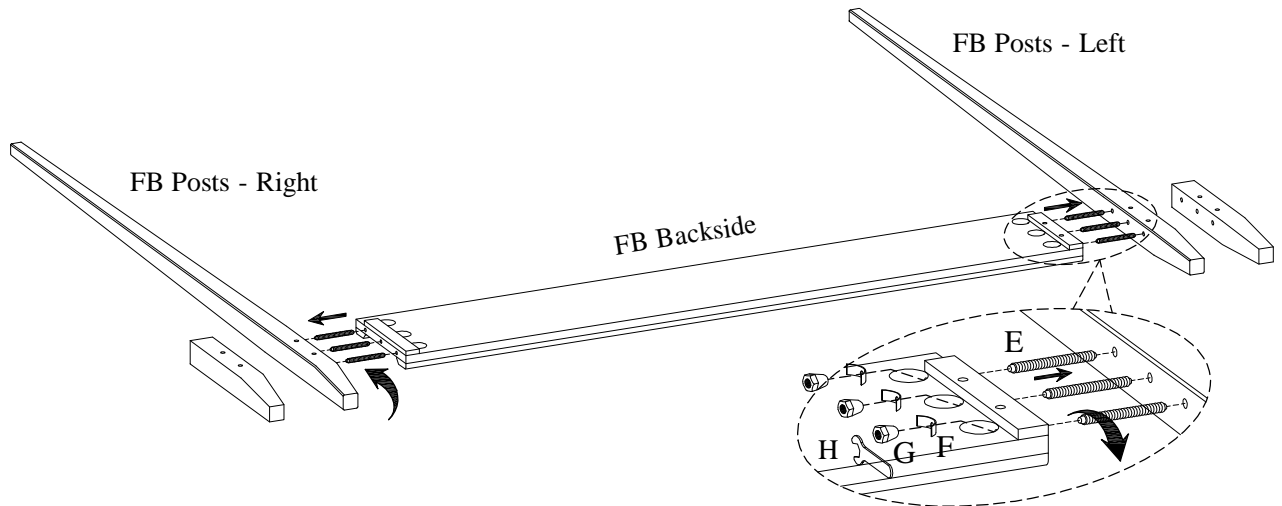

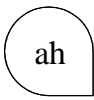

- ITEM NO: I3048-444P    Q/K Bed Tall Posts
- I3048-445P    Q/K Bed Short Posts
- I3048-406        King Rails
- I3048-410        Cal King Rails
- I3048-443        King HB & FB Panels

**STEP 3:** Screw the bolts (I) into HB & FB. Make sure the slat bearer is in the LOWER position. Align the bolts with the holes in the end of side rails and attach the side rails to HB & FB using half moon Washers (J) and hex nuts (K). Then use a hex wrench (L) to tighten all the nuts.

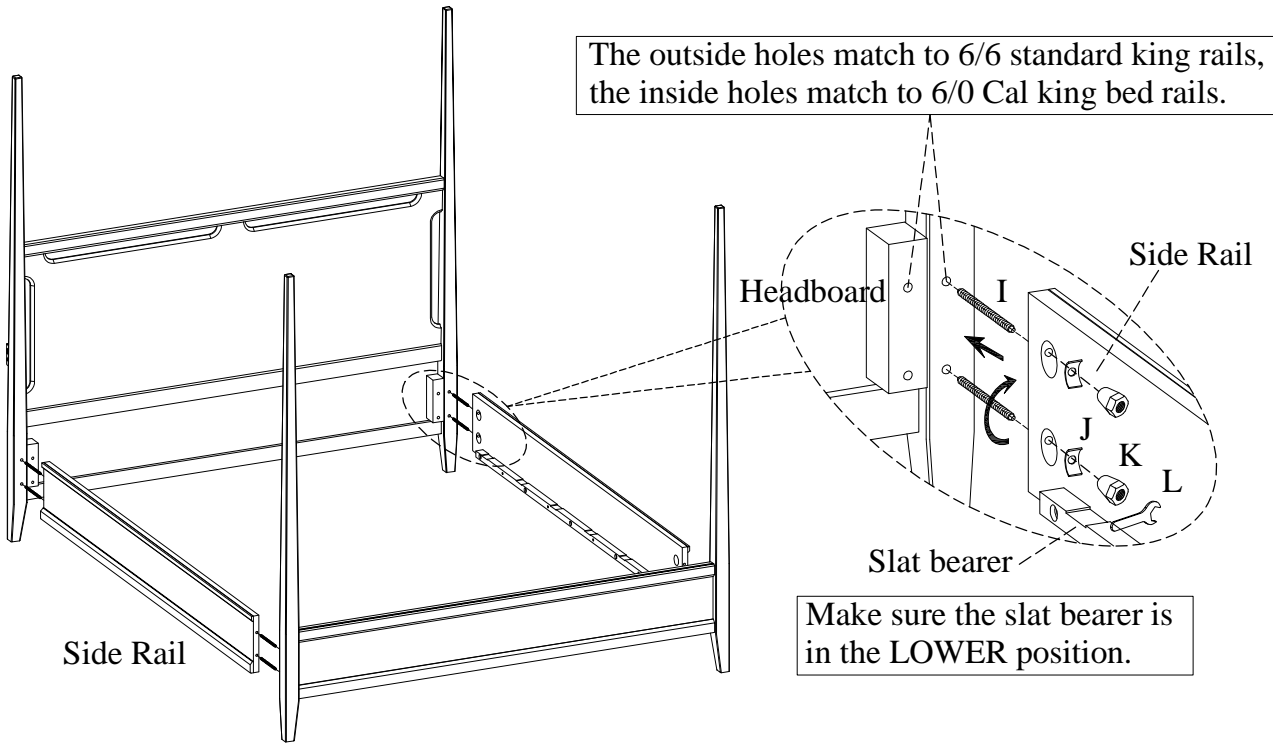

**STEP 4:** Attach the support legs to the slats as shown right.

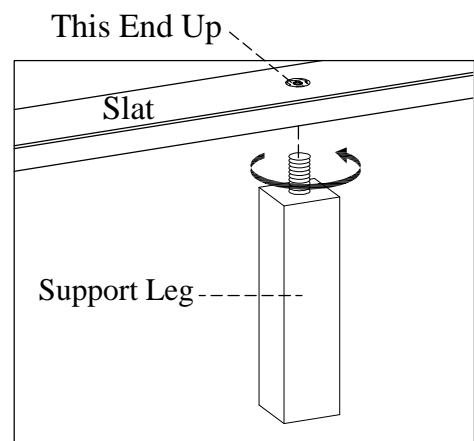

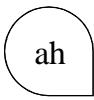

- ITEM NO: I3048-444P Q/K Bed Tall Posts  
 I3048-445P Q/K Bed Short Posts  
 I3048-406 King Rails  
 I3048-410 Cal King Rails  
 I3048-443 King HB & FB Panels

**STEP 5:** Arrange slats on the slat bearers. Make sure the slats are placed within the notches of each bearer and secured completely with wood screws (M).

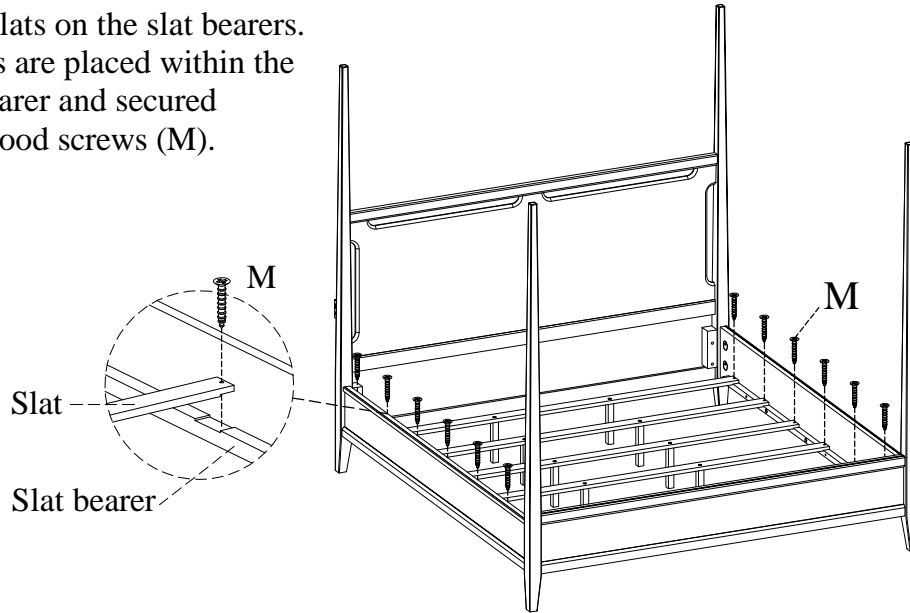

**STEP 6:** For Cal King bed, insert wood caps into the holes on headboard and footboard. For regular King bed, skip this step.

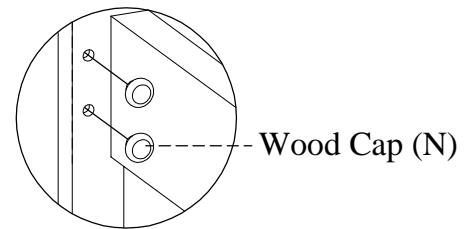

### FUNCTIONALITY INSTRUCTION

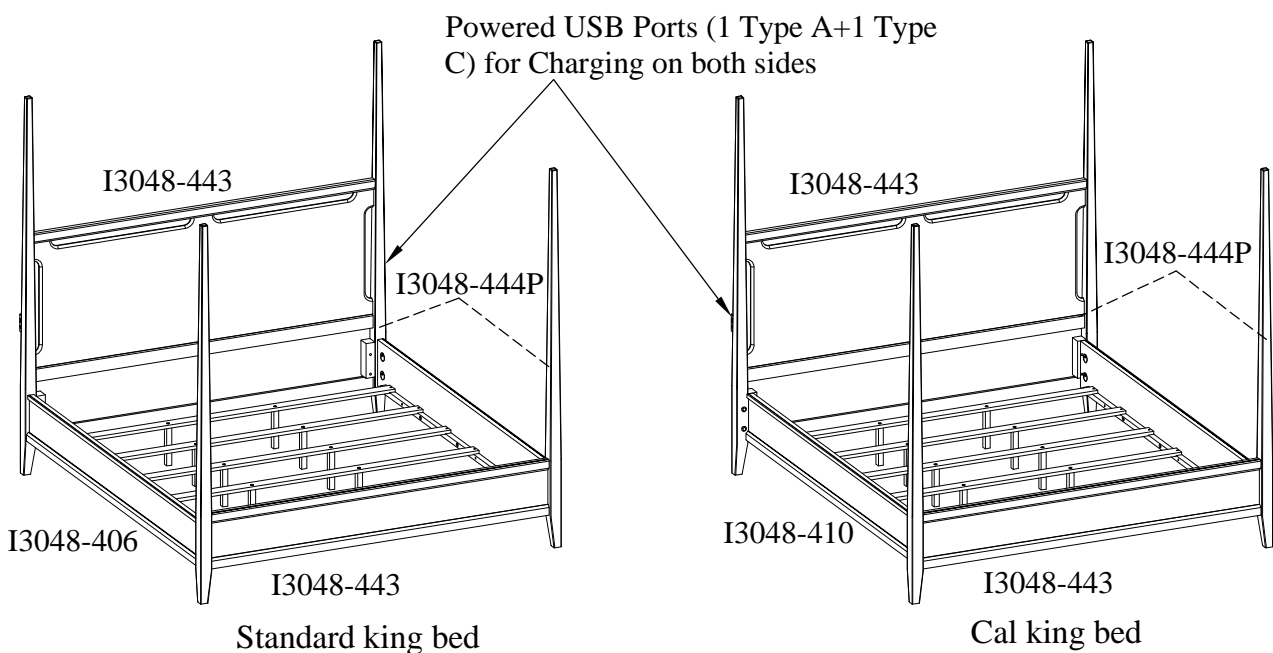

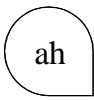

- ITEM NO: I3048-444P Q/K Bed Tall Posts  
 I3048-445P Q/K Bed Short Posts  
 I3048-406 King Rails  
 I3048-410 Cal King Rails  
 I3048-443 King HB & FB Panels

### FUNCTIONALITY INSTRUCTION

