



ITEM NO: I3048-6050 Extendable Dining Table

Thank you for purchasing this quality product. Be sure to check all packing material carefully for small parts that may come loose inside the carton during shipment.



UNIT SHOULD BE INSTALLED BY 2 OR MORE PERSONS.

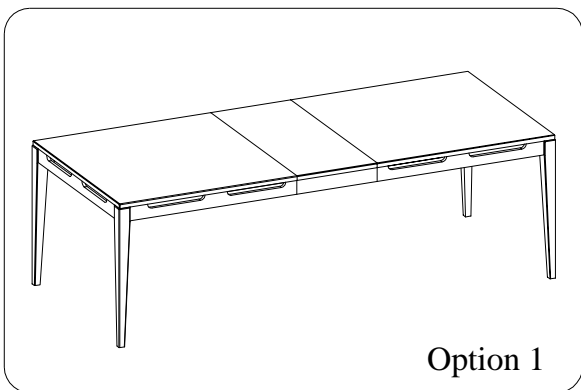

Option 1

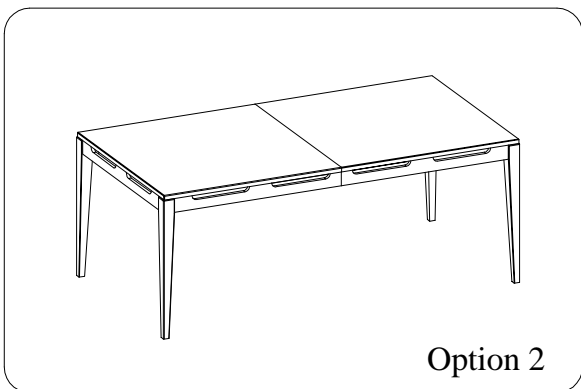

Option 2

TOOLS REQUIRED (NOT PROVIDED)	
PHILLIPS SCREWDRIVER	

HARDWARE LIST:			
No.	Description	Sketch	Quantity
A	Hex Nut Ø5/16"		8 PCS
B	Lock Washer Ø5/16"		8 PCS
C	Flat Washer Ø5/16" x 3/4"		8 PCS
D	Hex Wrench 12mm		1 PC

COMPONENTS LIST:			
No.	Description	Sketch	Quantity
1	Table Top		1 PC
2	Leg		4 PCS

FUNCTIONALITY INSTRUCTION

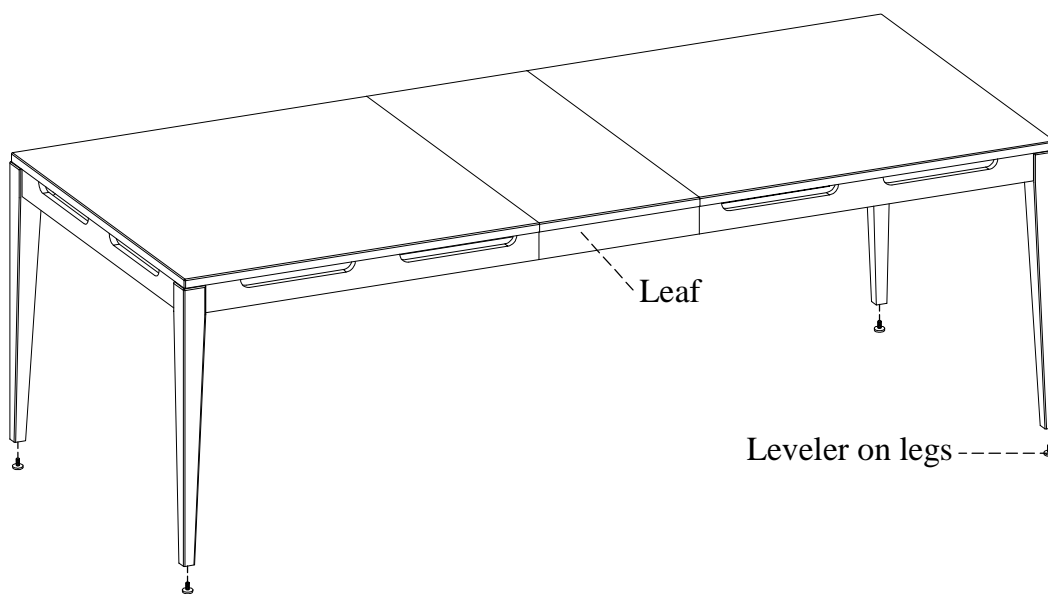

WARNING! Before using this product, please read, understand, and follow these instructions. Failure to follow each of these assembly instructions precisely may result in damage to the product and / or injury to the consumer.

FOR INDOOR USE ONLY



ITEM NO: I3048-6050 Extendable Dining Table

For OPTION 1:

STEP 1: Lay the table top face down on a soft surface. Attach the legs to table top by using 8 flat washers(C), lock washers(B) with hex nuts(A). Completely tighten all the nuts.

STEP 2: Remove 8 wood blocks by taking out 16 wood screws, then turn the assembled table to the upright position.

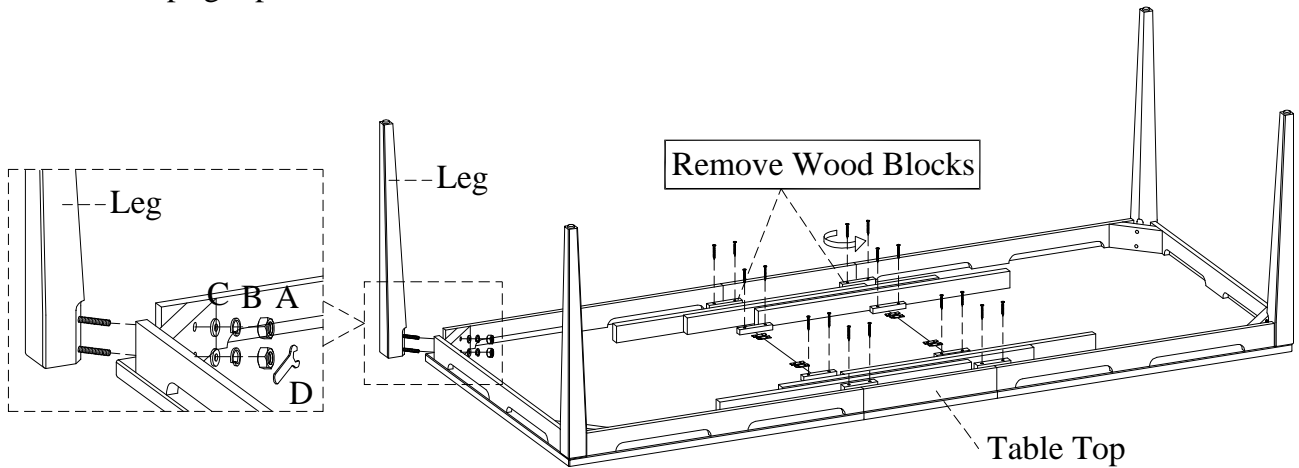

For OPTION 2:

STEP 3: Turn the table locks under the table top to the OFF position as shown below. Fully extend both sides of table as shown below.

STEP 4: Remove the leaf in opening and push ends of table together to close the gaps in table top. Turn the table locks to the ON position.

