

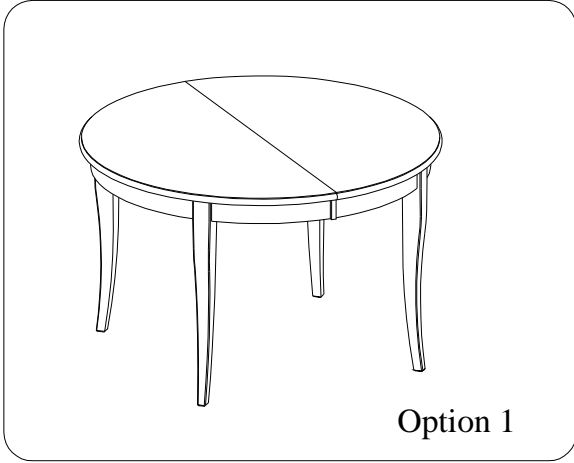

ITEM NO: I540-6000 Extendable Round Dining Table

Thank you for purchasing this quality product. Be sure to check all packing material carefully for small parts that may come loose inside the carton during shipment.



Option 1

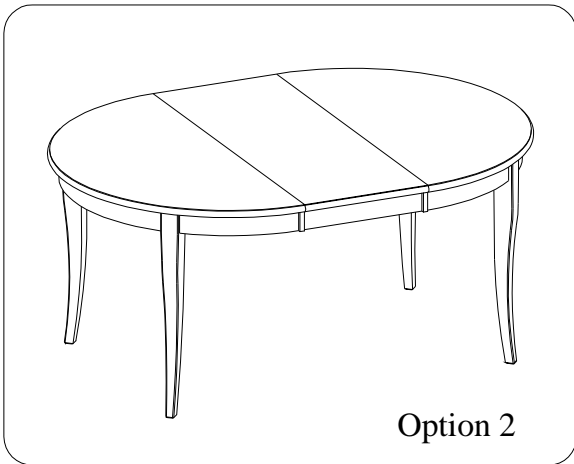

Option 2

TOOLS REQUIRED (NOT PROVIDED)
PHILLIPS SCREWDRIVER

HARDWARE LIST:			
No.	Description	Sketch	Quantity
A	Bolt Ø5/16" x 2-1/4"		8 PCS
B	Lock Washer Ø5/16"		8 PCS
C	Flat Washer Ø5/16" x 3/4"		8 PCS
D	Allen Wrench 4mm		1 PC

COMPONENTS LIST:			
No.	Description	Sketch	Quantity
1	Table Top		1 PC
2	Leaf		1 PC
3	Leg		4 PCS

FUNCTIONALITY INSTRUCTION

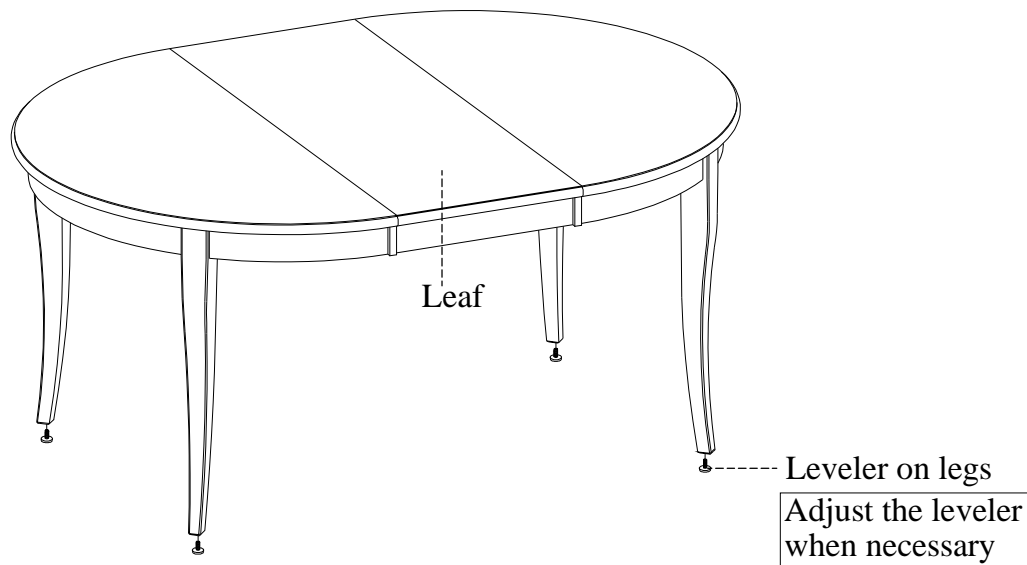

BEFORE USING THIS PRODUCT PLEASE READ, UNDERSTAND, AND FOLLOW THESE INSTRUCTIONS.
Save these instructions for future reference.

FOR INDOOR USE ONLY



ITEM NO: I540-6000 Extendable Round Dining Table

For OPTION 1:

STEP 1: Lay the table top face down on a soft surface. Attach the legs to table top by using 8 bolts(A), lock washers(B) and flat washers(C). Use the allen wrench(D) provided to tighten all the nuts. Turn the assembled table to the upright position.

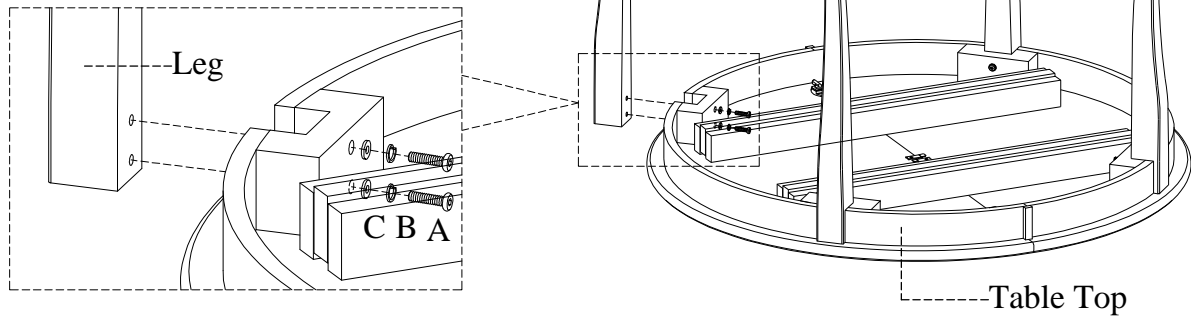

For OPTION 2:

STEP 2: Make the table locks under the table top at the OFF position as shown below. And pull the table top to both sides out completely.

STEP 3: Put the leaf in and push the table top until the table top fully closed. Make the table locks at the ON position.

