

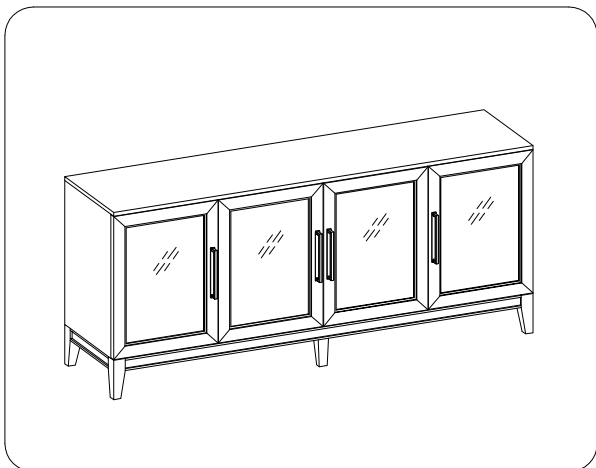

ITEM NO: I631-272 72" Console

Thank you for purchasing this quality product. Be sure to check all packing material carefully for small parts that may come loose inside the carton during shipment.



TOOLS REQUIRED (NOT PROVIDED)
PHILLIPS SCREWDRIVER

HARDWARE LIST:			
No.	Description	Sketch	Quantity
A	Hex Bolt Ø1/4" x 2"		8 PCS
B	Hex Bolt Ø1/4" x 1-1/2"		2 PCS
C	Lock Washer Ø1/4"		10 PCS
D	Flat Washer Ø1/4" x 3/4"		10 PCS
E	Allen Wrench 4mm		1 PC

COMPONENTS LIST:			
No.	Description	Sketch	Quantity
1	Case		1 PC
2	Side Leg		4 PCS
3	Central Leg		1 PC
4	Support Leg		1 PC

FUNCTIONALITY INSTRUCTION

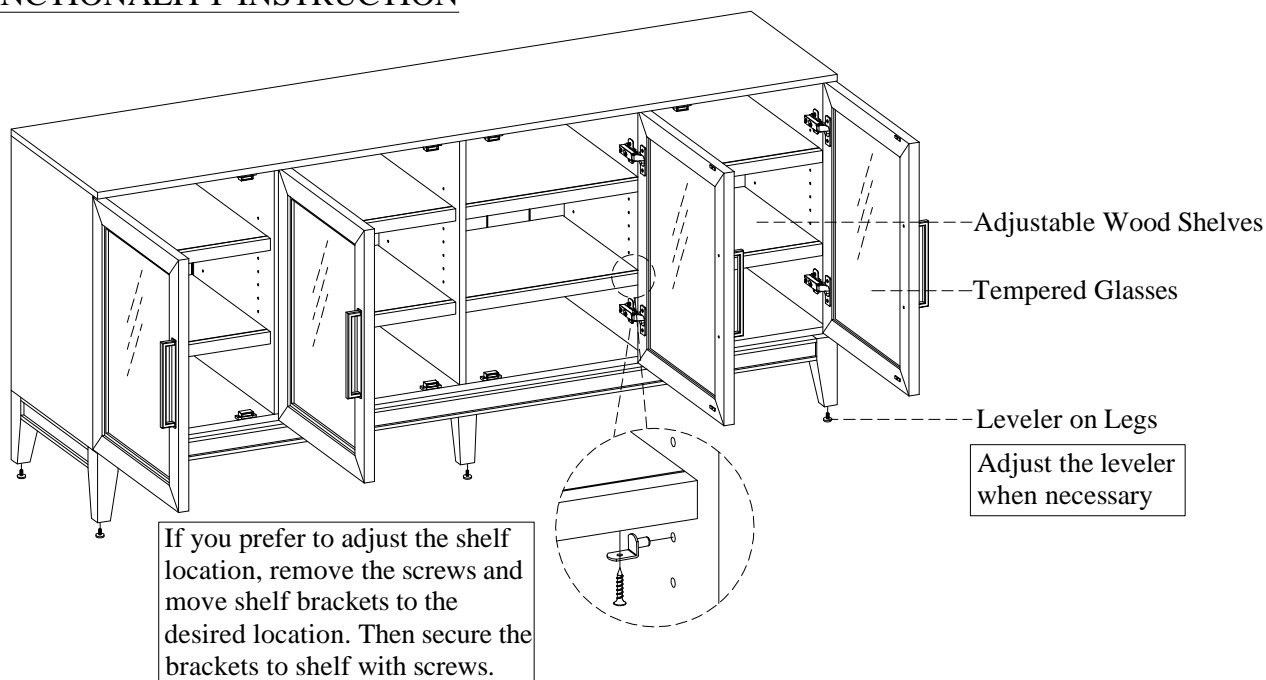

BEFORE USING THIS PRODUCT PLEASE READ, UNDERSTAND, AND FOLLOW THESE INSTRUCTIONS. Save these instructions for future reference.

FOR INDOOR USE ONLY



ITEM NO: I631-272 72" Console

STEP 1: Lay the case face down on a soft surface. Attach the side legs and central leg to case by using 8 bolts(A), 2 bolts(B), 10 lock washers(C), 10 flat washers(D). Completely tighten all bolts. Install the support leg as well. Once legs are all secure, turn the assembled console to the upright position.

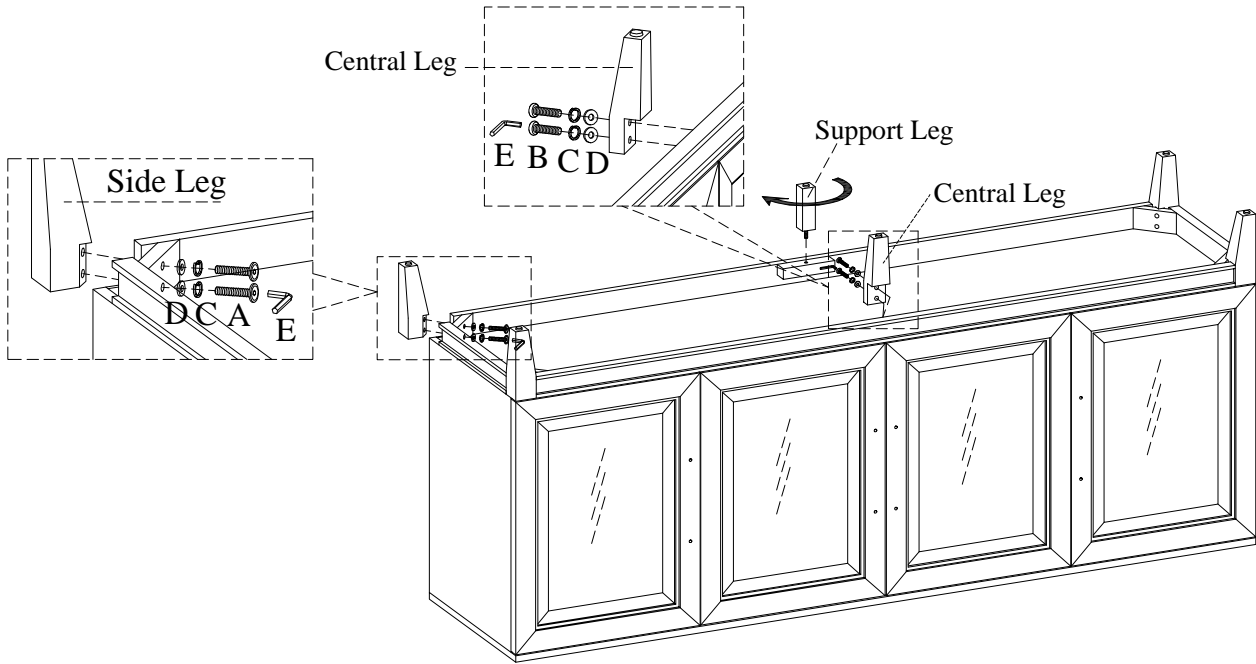

STEP 2: Reverse each handle by removing the screws while each door is open and attach all handles to the front of the doors with screws as shown below.

