

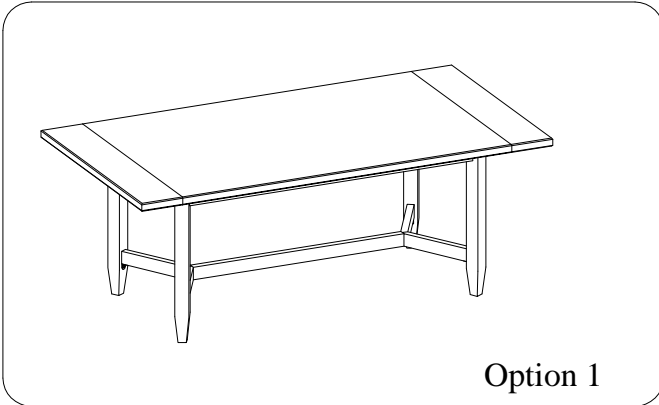

ITEM NO: I631-6030 Ext Trestle Dining Table

Thank you for purchasing this quality product. Be sure to check all packing material carefully for small parts that may come loose inside the carton during shipment.



Option 1

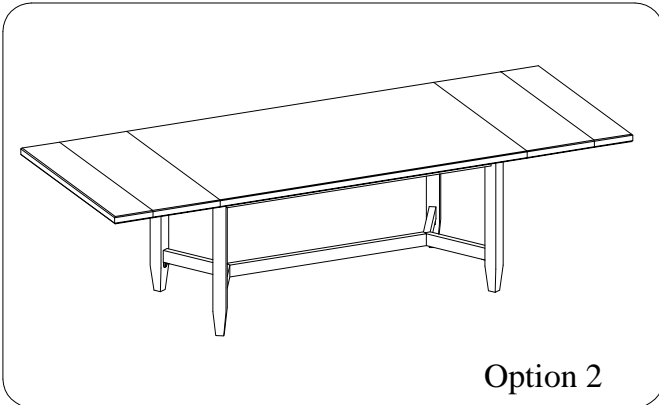

Option 2

TOOLS REQUIRED (NOT PROVIDED)
PHILLIPS SCREWDRIVER

HARDWARE LIST:			
No.	Description	Sketch	Quantity
A	Hex Bolt Ø5/16" x 2"		8 PCS
B	Lock Washer Ø5/16"		8 PCS
C	Flat Washer Ø5/16" x 3/4"		8 PCS
D	Hex Wrench 12mm		1 PC
E	Bolt Ø1/4" x 3/4"		8 PCS
F	Lock Washer Ø1/4"		8 PCS
G	Flat Washer Ø1/4" x 3/4"		8 PCS
H	Allen Wrench 4mm		1 PC
I	Metal Bracket		4 PCS

COMPONENTS LIST:			
No.	Description	Sketch	Quantity
1	Table Top		1 PC
2	Leg		4 PCS
3	Wood Stretcher		1 PC
4	Leaf		2 PCS

FUNCTIONALITY INSTRUCTION

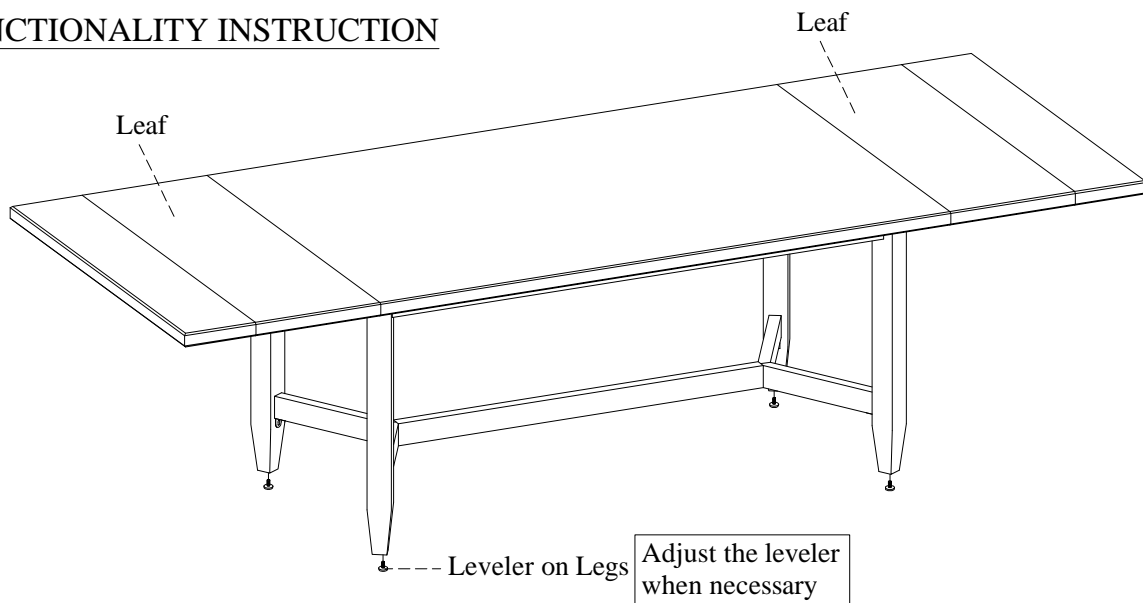

BEFORE USING THIS PRODUCT PLEASE READ, UNDERSTAND, AND FOLLOW THESE INSTRUCTIONS. Save these instructions for future reference.

FOR INDOOR USE ONLY



ITEM NO: I631-6030 Ext Trestle Dining Table

For OPTION 1:

STEP 1: Lay the table top face down on a soft surface. Attach the legs to table top by using 8 bolts (A), lock washers (B) and flat washers (C) with a hex wrench (D). Do not completely tighten all the bolts.

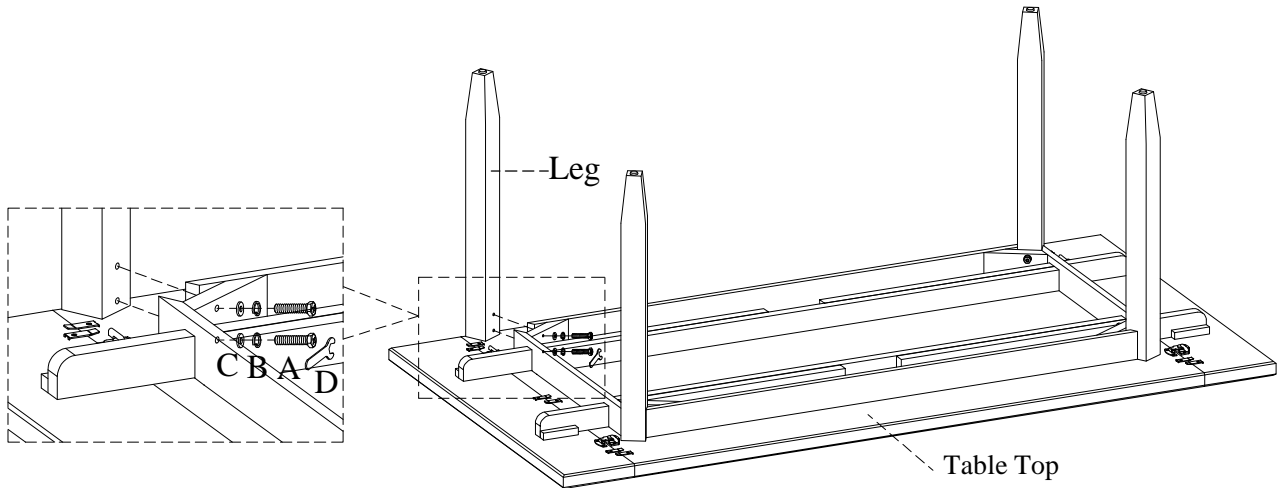

STEP 2: Attach the wood stretcher to legs with 4 metal bracket (I) by using 8 bolts (E), lock washers (F) and flat washers (G). Then use an allen wrench (H) and a hex wrench (D) to tighten all the bolts. Turn the assembled table to the upright position.

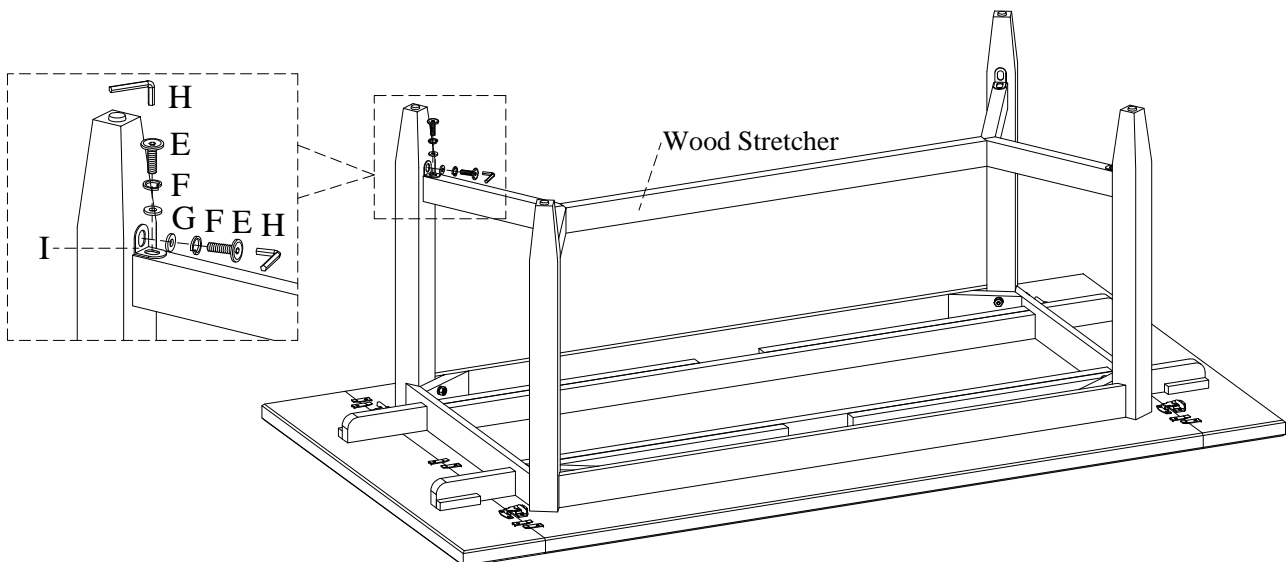



ITEM NO: I631-6030 Ext Trestle Dining Table

For OPTION 2:

STEP 3: Make the table locks under the table top at the OFF position as shown below. And pull the table top to both sides out completely.

STEP 4: Put the leaf in and push the table top until the table top fully closed. Make the table locks at the ON position.

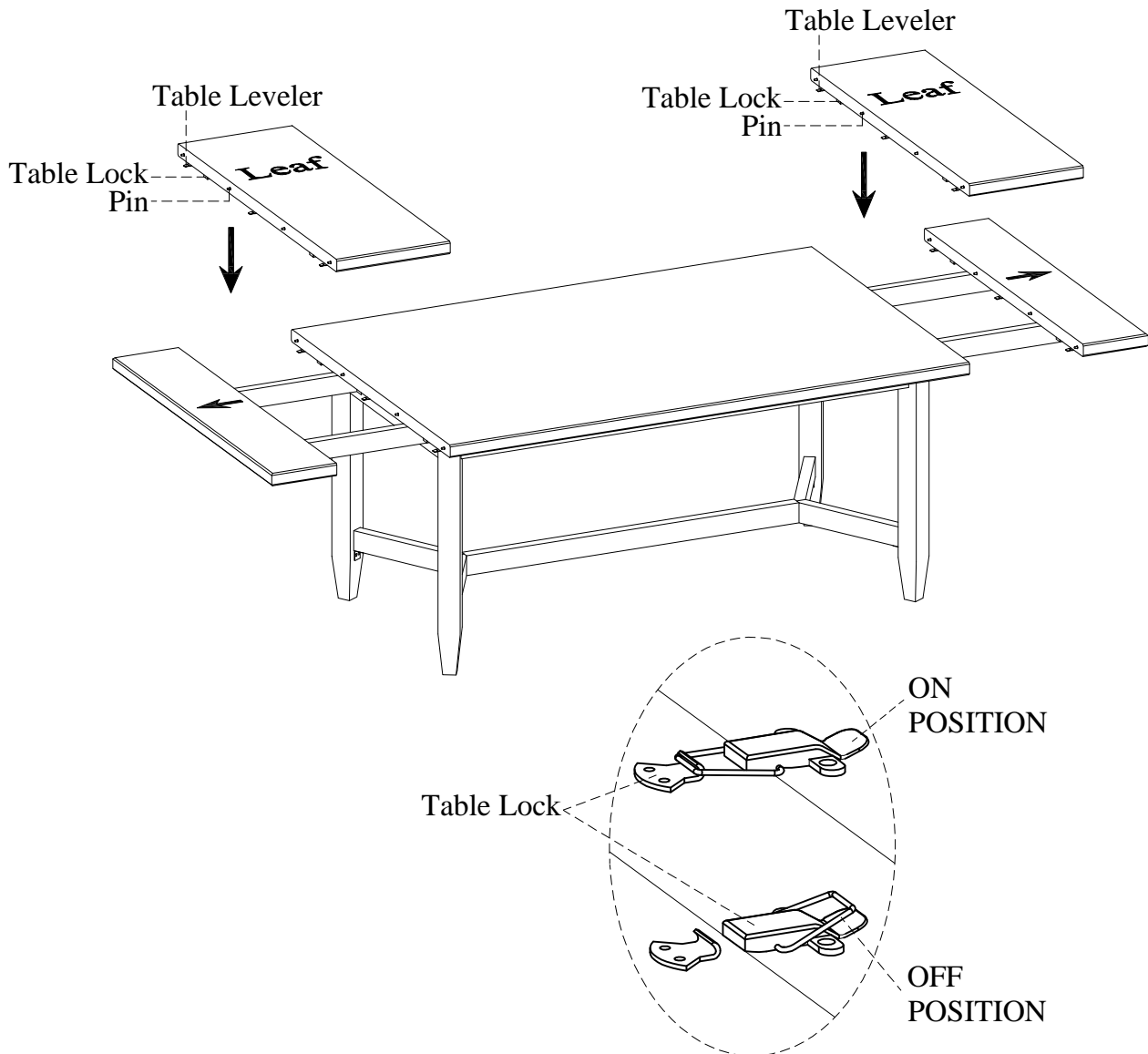



ITEM NO: I631-6640S Dining Side Chair w/ Uph Seat (2/Ctn)

Thank you for purchasing this quality product. Be sure to check all packing material carefully for small parts that may come loose inside the carton during shipment.

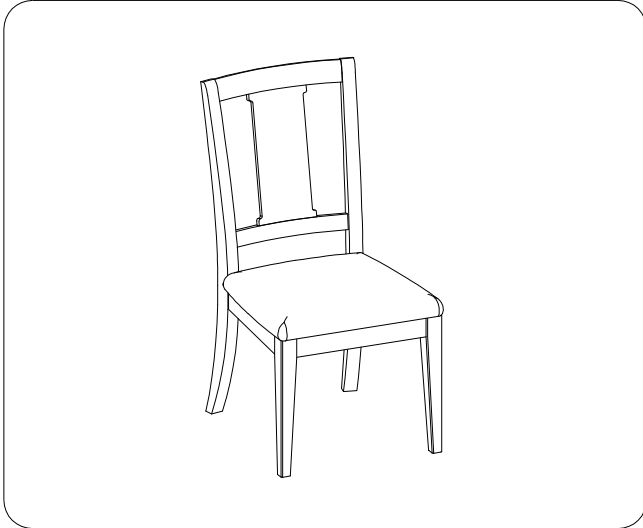

TOOLS REQUIRED (NOT PROVIDED)

PHILLIPS SCREWDRIVER

HARDWARE LIST:

No.	Description	Sketch	Quantity
A	Hex Bolt Ø5/16" x 3-1/4"		4 PCS
B	Hex Bolt Ø5/16" x 1-3/4"		2 PCS
C	Lock Washer Ø5/16"		10 PCS
D	Flat Washer Ø5/16" x 3/4"		10 PCS
E	Hex Wrench 12mm		1 PC
F	Hex Nut Ø5/16"		4 PCS

COMPONENTS LIST:

No.	Description	Sketch	Quantity
1	Chair Back		1 PC
2	Chair Seat		1 PC
3	Front Leg		2 PCS

FUNCTIONALITY INSTRUCTION

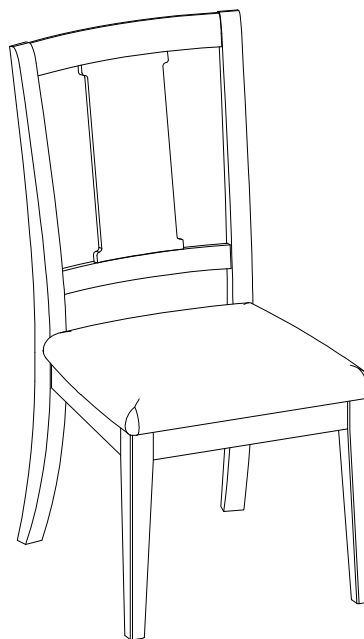

BEFORE USING THIS PRODUCT PLEASE READ, UNDERSTAND, AND FOLLOW THESE INSTRUCTIONS.

Save these instructions for future reference.

FOR INDOOR USE ONLY

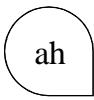

ITEM NO: I631-6640S Dining Side Chair w/ Uph Seat (2/Ctn)

STEP 1: Attach the front legs to chair seat by using 4 lock washers (C) and flat washers (D) with hex nuts (F). Then use a hex wrench (E) to tighten all the bolts.

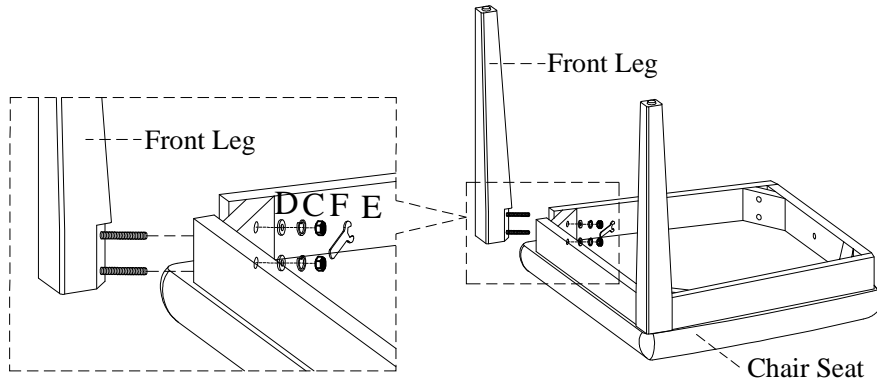

STEP 2: Attach the chair seat to chair back by using 4 bolts (A), 2 bolts (B), 6 lock washers (C), 6 flat washers (D) with a hex wrench (E). Completely tighten all bolts. Turn the assembled chair to the upright position.

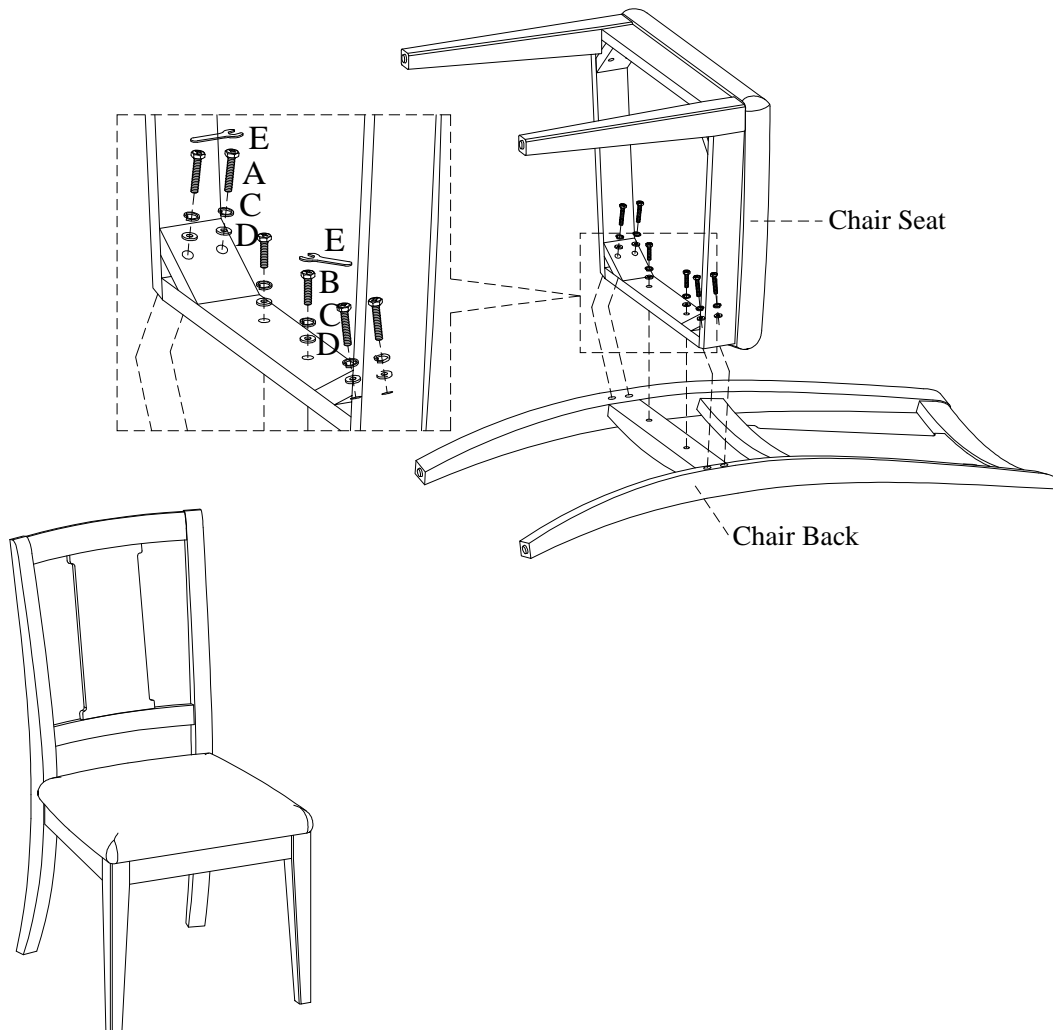



ITEM NO: I631-6600S Upholstered Dining Chair (2/Ctn)

Thank you for purchasing this quality product. Be sure to check all packing material carefully for small parts that may come loose inside the carton during shipment.

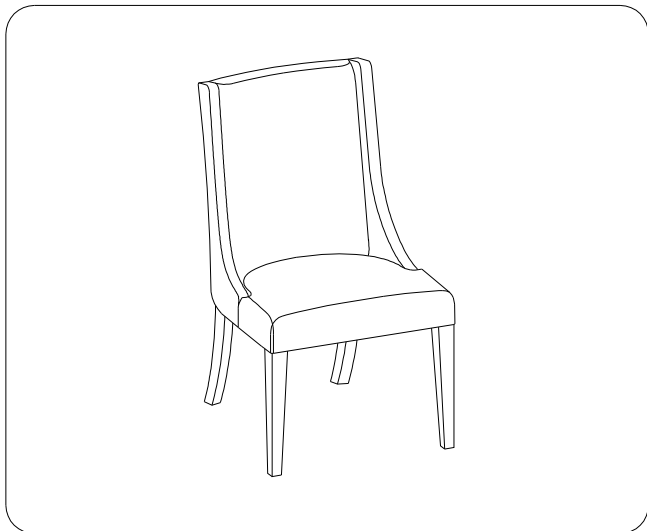

TOOLS REQUIRED (NOT PROVIDED)

PHILLIPS SCREWDRIVER

HARDWARE LIST:

No.	Description	Sketch	Quantity
A	Bolt Ø5/16" x 2"		8 PCS
B	Lock Washer Ø5/16"		8 PCS
C	Flat Washer Ø5/16" x 3/4"		8 PCS
D	Allen Wrench 4mm		1 PC

COMPONENTS LIST:

No.	Description	Sketch	Quantity
1	Chair Seat		1 PC
2	Front Leg		2 PCS
3	Back Leg		2 PCS

FUNCTIONALITY INSTRUCTION

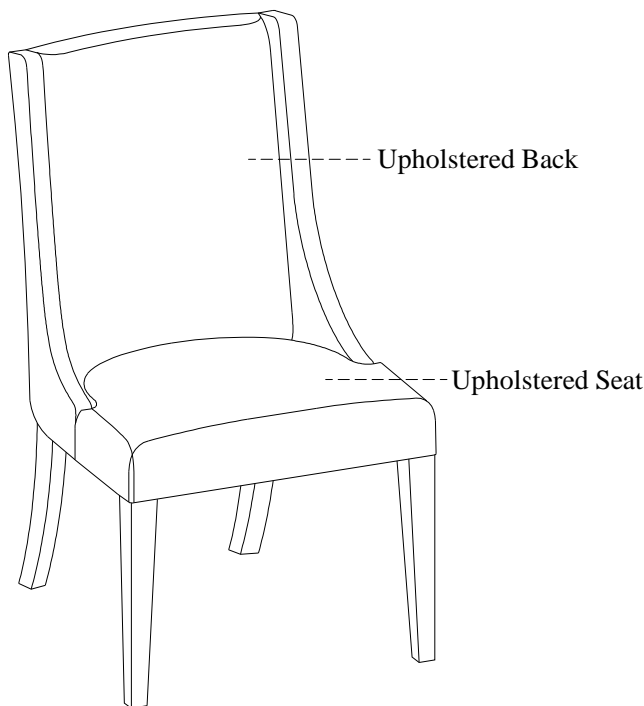

BEFORE USING THIS PRODUCT PLEASE READ, UNDERSTAND, AND FOLLOW THESE INSTRUCTIONS.

Save these instructions for future reference.

FOR INDOOR USE ONLY

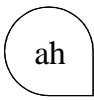

ITEM NO: I631-6600S Upholstered Dining Chair (2/Ctn)

STEP 1: Attach the front legs and back legs to chair seat by using 8 bolts (A), lock washers (B) and flat washers (C) with an allen wrenches (D) as shown below. Completely tighten all bolts. Turn the assembled chair to the upright position.

