



ITEM NO: I644-412 Queen Panel HB
 I644-402 Queen Rails
 I644-403 Queen Low Profile FB

Thank you for purchasing this quality product. Be sure to check all packing material carefully for small parts that may come loose inside the carton during shipment.



UNIT SHOULD BE INSTALLED BY 2 OR MORE PERSONS.

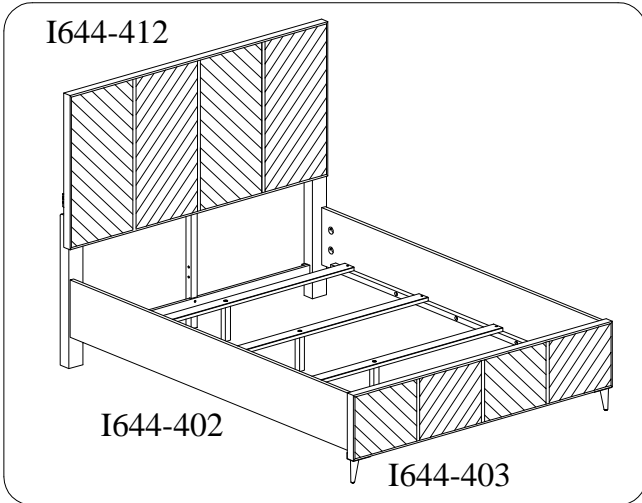

All Beds need to be set up in the exact final location so that after full assembly it will not need to be moved. Moving the bed will cause the support legs to move out of perpendicular (90 degree), weaken the support system, and may allow the bed to collapse.

TOOLS REQUIRED (NOT PROVIDED)
PHILLIPS SCREWDRIVER

HARDWARE LIST: I644-412			
No.	Description	Sketch	Quantity
A	Bolt Ø5/16" x 1-1/2"		2 PCS
B	Bolt Ø5/16" x 2"		10 PCS
C	Lock Washer Ø5/16"		12 PCS
D	Flat Washer Ø5/16" x 3/4"		12 PCS
E	Allen Wrench 4mm		1 PC

COMPONENTS LIST: I644-412			
No.	Description	Sketch	Quantity
1	Headboard (HB)		1 PC
2	Left Leg		1 PC
3	Right Leg		1 PC
4	Wood Stretcher		1 PC
5	Center Support Leg		1 PC

HARDWARE LIST: I644-402			
No.	Description	Sketch	Quantity
F	Hanger Bolt Ø5/16" x 3"		8 PCS
G	Half Moon Washer Ø5/16"		8 PCS
H	Hex Nut Ø5/16"		8 PCS
I	Hex Wrench 12mm		1 PC
J	Wood Screw #8 x 1-1/4"		8 PCS

COMPONENTS LIST: I644-402			
No.	Description	Sketch	Quantity
1	Bed rails		2 PCS
2	Slats		4 PCS

HARDWARE LIST: I644-403			
No.	Description	Sketch	Quantity
K	Bolt Ø5/16" x 1"		6 PCS
L	Lock Washer Ø5/16"		6 PCS
M	Flat Washer Ø5/16" x 3/4"		6 PCS
N	Allen Wrench 4mm		1 PC

COMPONENTS LIST: I644-403			
No.	Description	Sketch	Quantity
1	Footboard (FB)		1 PC
2	Metal Leg Left		1 PC
3	Metal Leg Right		1 PC
4	Support Leg (for slat)		4 PCS

BEFORE USING THIS PRODUCT PLEASE READ, UNDERSTAND, AND FOLLOW THESE INSTRUCTIONS. Save these instructions for future reference.

FOR INDOOR USE ONLY



ITEM NO: I644-412 Queen Panel HB
 I644-402 Queen Rails
 I644-403 Queen Low Profile FB

STEP 1: Lay the headboard face down on a soft surface. Attach the left leg and right leg to headboard by using 8 bolts (B), lock washers (C) and flat washers (D). Do not completely tighten bolts.

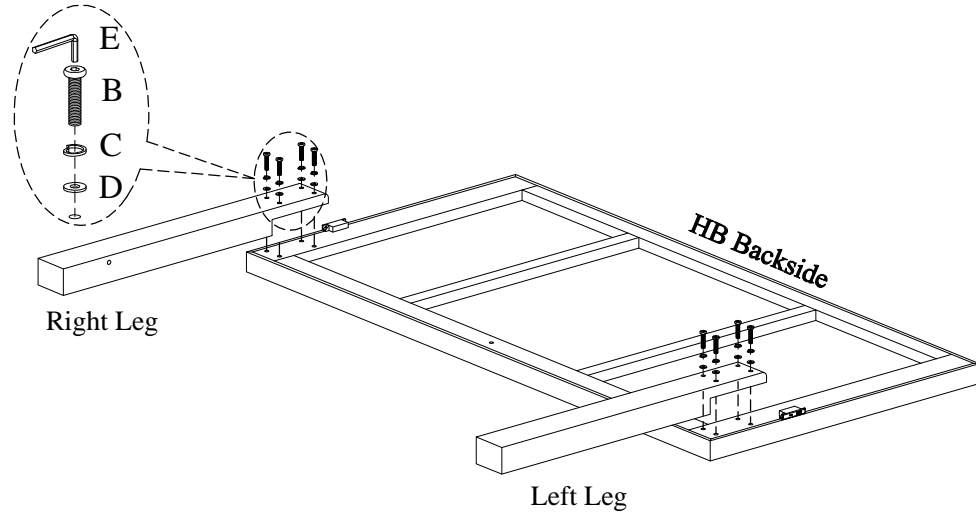

STEP 2: Attach the wood stretcher to the legs by using 2 bolts (B), lock washers (C) and flat washers (D).

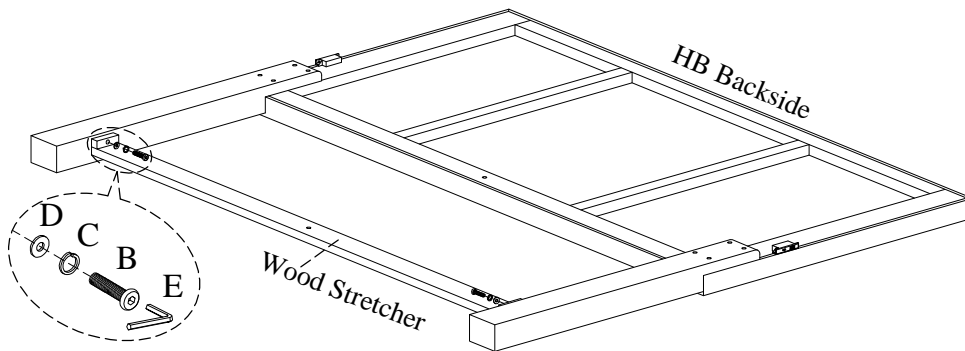

STEP 3: Attach the center support leg to headboard and wood stretcher by using 2 bolts (A), lock washers (C) and flat washers (D). Completely tighten all bolts.

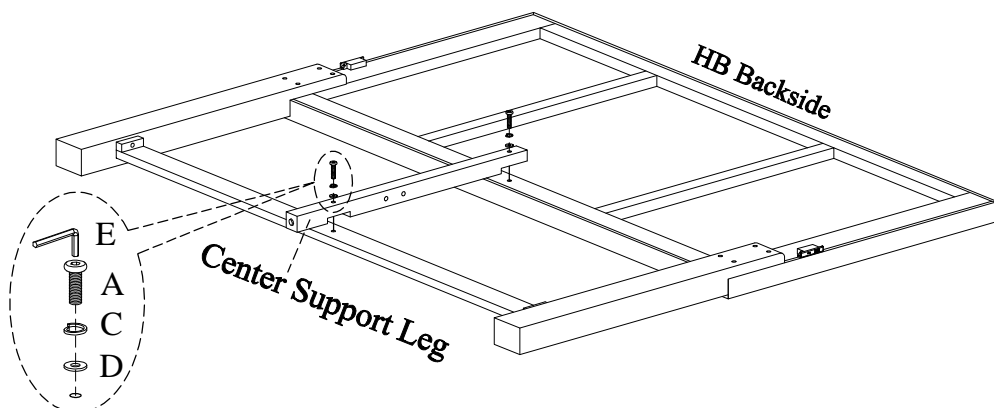



ITEM NO: I644-412 Queen Panel HB
 I644-402 Queen Rails
 I644-403 Queen Low Profile FB

STEP 4: Put the footboard upside down on a soft surface. Attach the metal leg left and metal leg right to footboard by using 6 bolts (K), lock washers (L) and flat washers (M). Completely tighten all bolts.

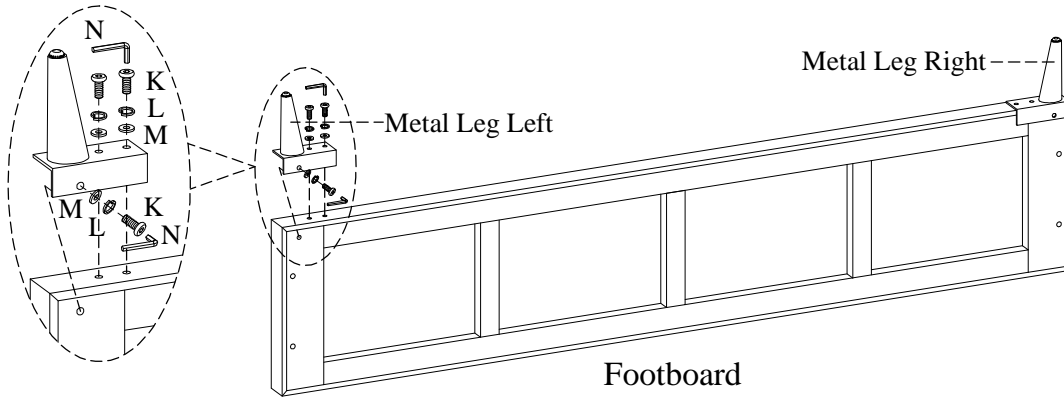

STEP 5: Screw the bolts (F) into HB & FB. Make sure the slat bearer is in the LOWER position. Align the bolts with the holes in the end of side rails and attach the side rails to HB & FB using half moon washers (G) and nuts (H). Then use a hex wrench (I) to tighten all the nuts.

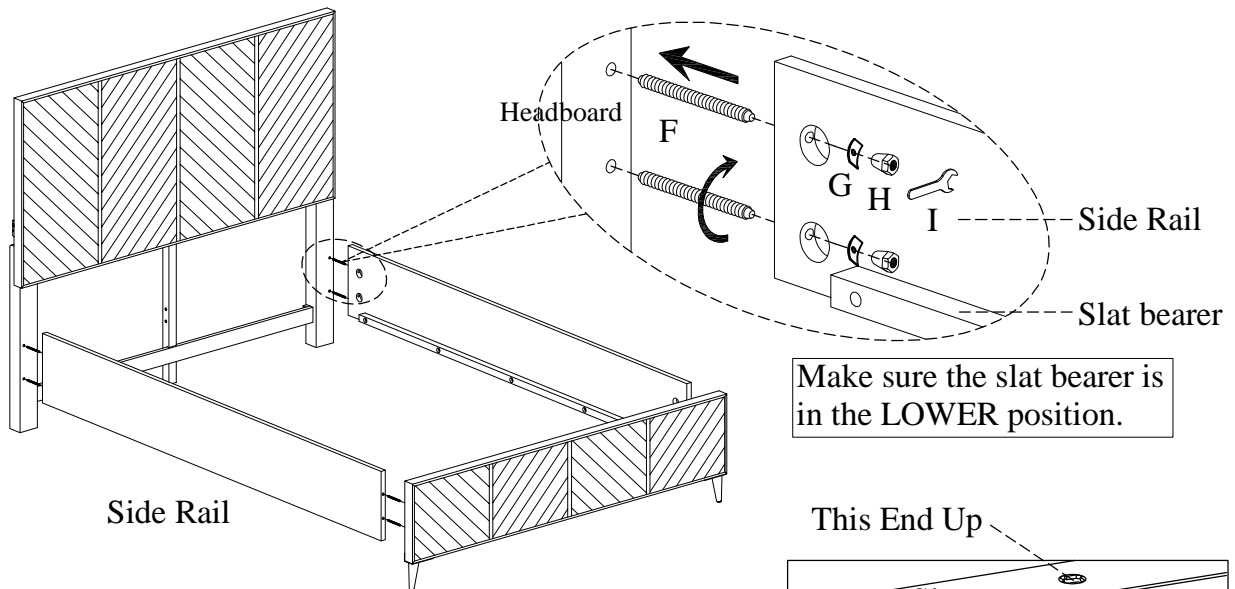

STEP 6: Attach the support legs to the slats as shown.

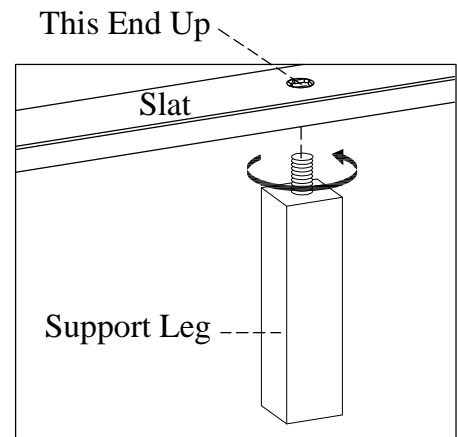

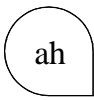

ITEM NO: I644-412 Queen Panel HB
I644-402 Queen Rails
I644-403 Queen Low Profile FB

STEP 7: Arrange the slats on the slat bearers equally and attach to the slat bearers with wood screws (J).

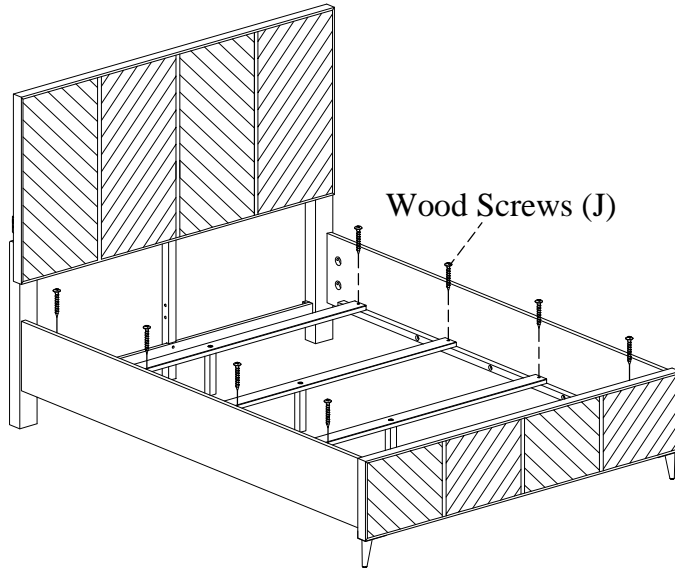

FUNCTIONALITY INSTRUCTION

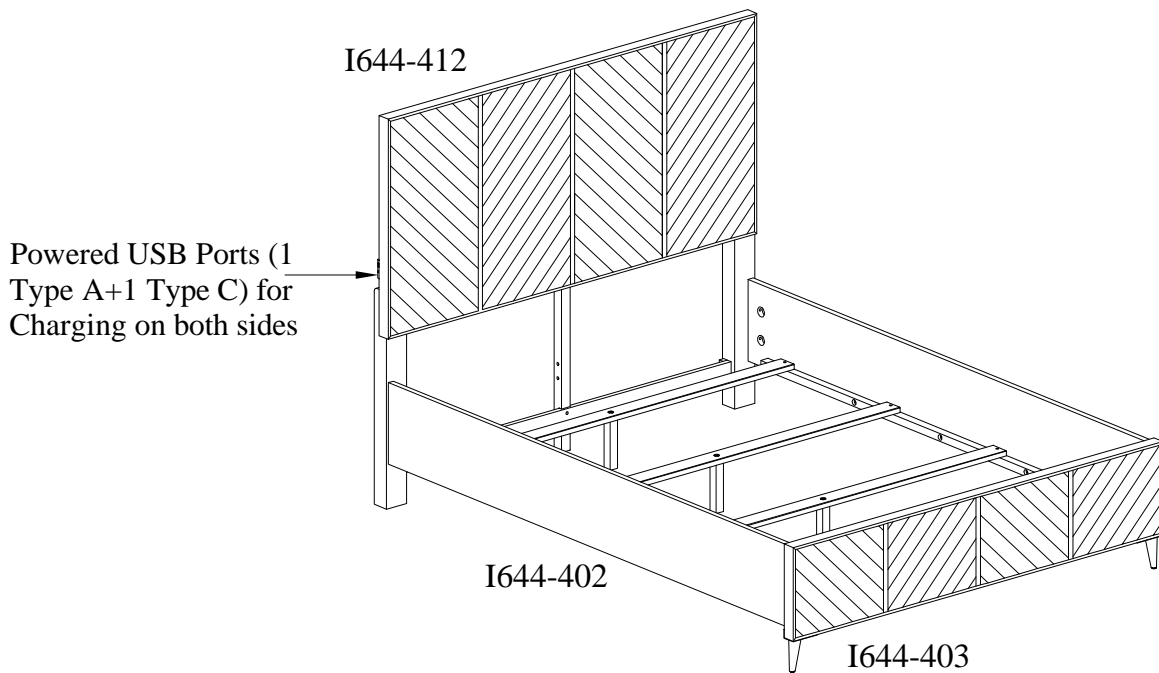



ITEM NO: I644-415 King Panel HB
 I644-406 King Rails
 I644-410 Cal King Rails
 I644-407 King Low Profile FB

Thank you for purchasing this quality product. Be sure to check all packing material carefully for small parts that may come loose inside the carton during shipment.



UNIT SHOULD BE INSTALLED BY 2 OR MORE PERSONS.

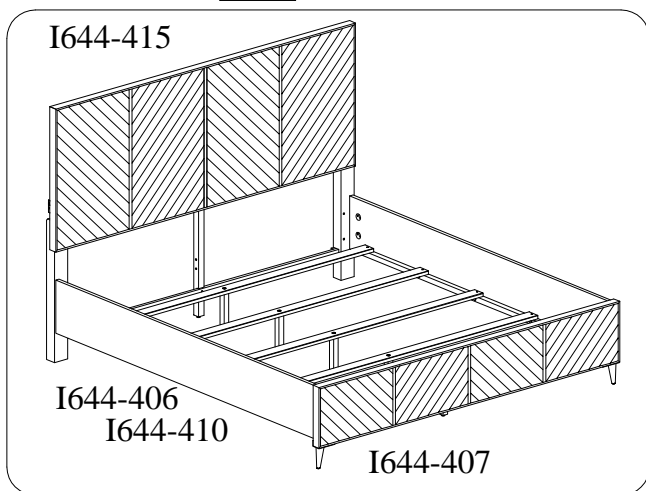

All Beds need to be set up in the exact final location so that after full assembly it will not need to be moved. Moving the bed will cause the support legs to move out of perpendicular (90 degree), weaken the support system, and may allow the bed to collapse.

TOOLS REQUIRED (NOT PROVIDED)
PHILLIPS SCREWDRIVER

HARDWARE LIST: I644-415

No.	Description	Sketch	Quantity
A	Bolt Ø5/16" x 1-1/2"		2 PCS
B	Bolt Ø5/16" x 2"		10 PCS
C	Lock Washer Ø5/16"		12 PCS
D	Flat Washer Ø5/16" x 3/4"		12 PCS
E	Allen Wrench 4mm		1 PC

HARDWARE LIST: I644-406/410

No.	Description	Sketch	Quantity
F	Hanger Bolt Ø5/16" x 3"		8 PCS
G	Half Moon Washer Ø5/16"		8 PCS
H	Hex Nut Ø5/16"		8 PCS
I	Hex Wrench 12mm		1 PC
J	Wood Screw #8 x 1-1/4"		10 PCS
K	Wood Cap (only for 410)		8 PCS

HARDWARE LIST: I644-407

No.	Description	Sketch	Quantity
L	Bolt Ø5/16" x 1"		6 PCS
M	Lock Washer Ø5/16"		6 PCS
N	Flat Washer Ø5/16" x 3/4"		6 PCS
O	Allen Wrench 4mm		1 PC

COMPONENTS LIST: I644-415

No.	Description	Sketch	Quantity
1	Headboard (HB)		1 PC
2	Left Leg		1 PC
3	Right Leg		1 PC
4	Wood Stretcher		1 PC
5	Center Support Leg		1 PC

COMPONENTS LIST: I644-406

No.	Description	Sketch	Quantity
1	Bed rails		2 PCS
2	Slats		5 PCS

COMPONENTS LIST: I644-410

No.	Description	Sketch	Quantity
1	Bed rails		2 PCS
2	Slats		5 PCS

COMPONENTS LIST: I644-407

No.	Description	Sketch	Quantity
1	Footboard (FB)		1 PC
2	Metal Leg Left		1 PC
3	Metal Leg Right		1 PC
4	Support Leg (for slat)		5 PCS

BEFORE USING THIS PRODUCT PLEASE READ, UNDERSTAND, AND FOLLOW THESE INSTRUCTIONS.
 Save these instructions for future reference.

FOR INDOOR USE ONLY

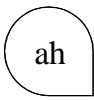

- | | |
|-------------------|---------------------|
| ITEM NO: I644-415 | King Panel HB |
| I644-406 | King Rails |
| I644-410 | Cal King Rails |
| I644-407 | King Low Profile FB |

STEP 1: Lay the headboard face down on a soft surface. Attach the left leg and right leg to headboard by using 8 bolts (B), lock washers (C) and flat washers (D). Do not completely tighten bolts.

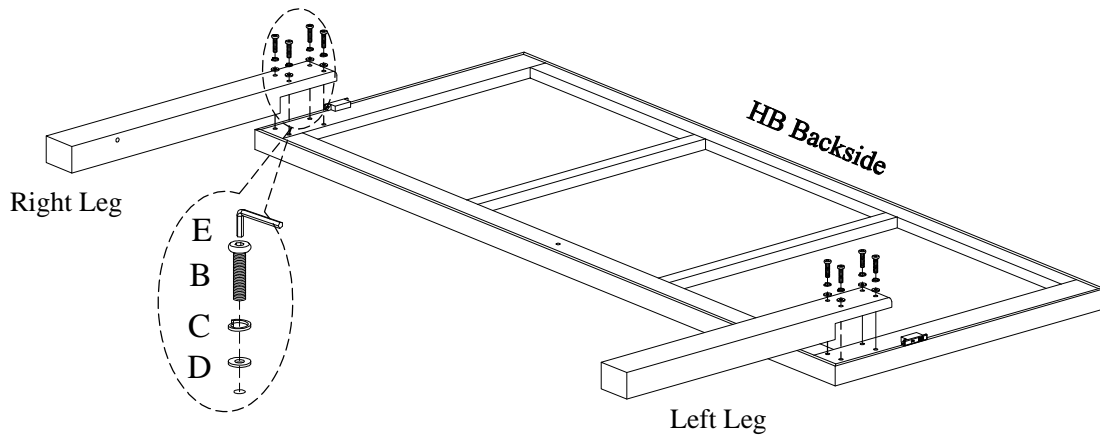

STEP 2: Attach the wood stretcher to the legs by using 2 bolts (B), lock washers (C) and flat washers (D).

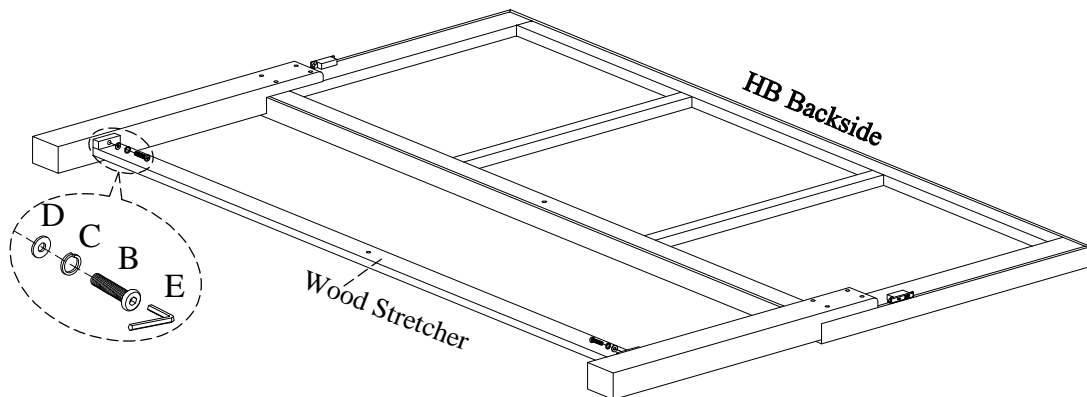

STEP 3: Attach the center support leg to headboard and wood stretcher by using 2 bolts (A), lock washers (C) and flat washers (D). Completely tighten all bolts.

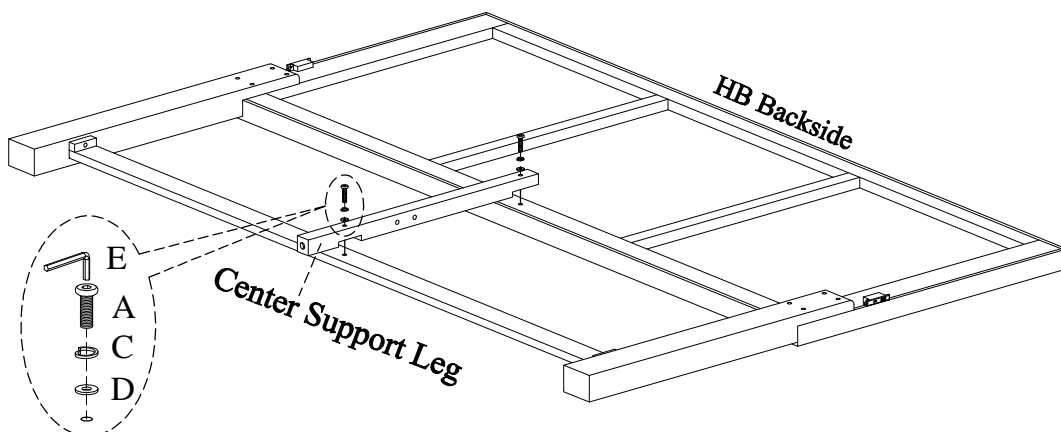

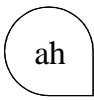

- ITEM NO: I644-415 King Panel HB
- I644-406 King Rails
- I644-410 Cal King Rails
- I644-407 King Low Profile FB

STEP 4: Put the footboard upside down on a soft surface. Attach the metal leg left and metal leg right to footboard by using 6 bolts (L), lock washers (M) and flat washers (N). Completely tighten all bolts.

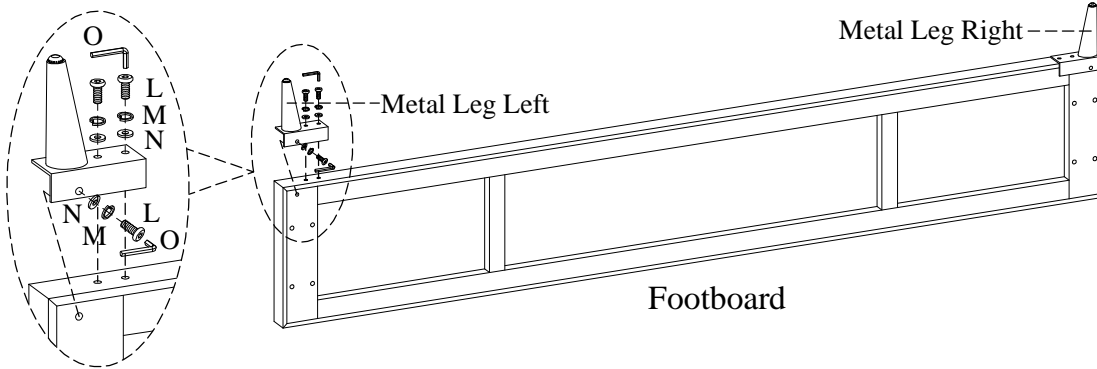

STEP 5: Screw the bolts (F) into HB & FB. Make sure the slat bearer is in the LOWER position. Align the bolts with the holes in the end of side rails and attach the side rails to HB & FB using half moon washers (G) and nuts (H). Then use a hex wrench (I) to tighten all the nuts.

The outside holes match to 6/6 standard king rails, the inside holes match to 6/0 Cal king bed rails.

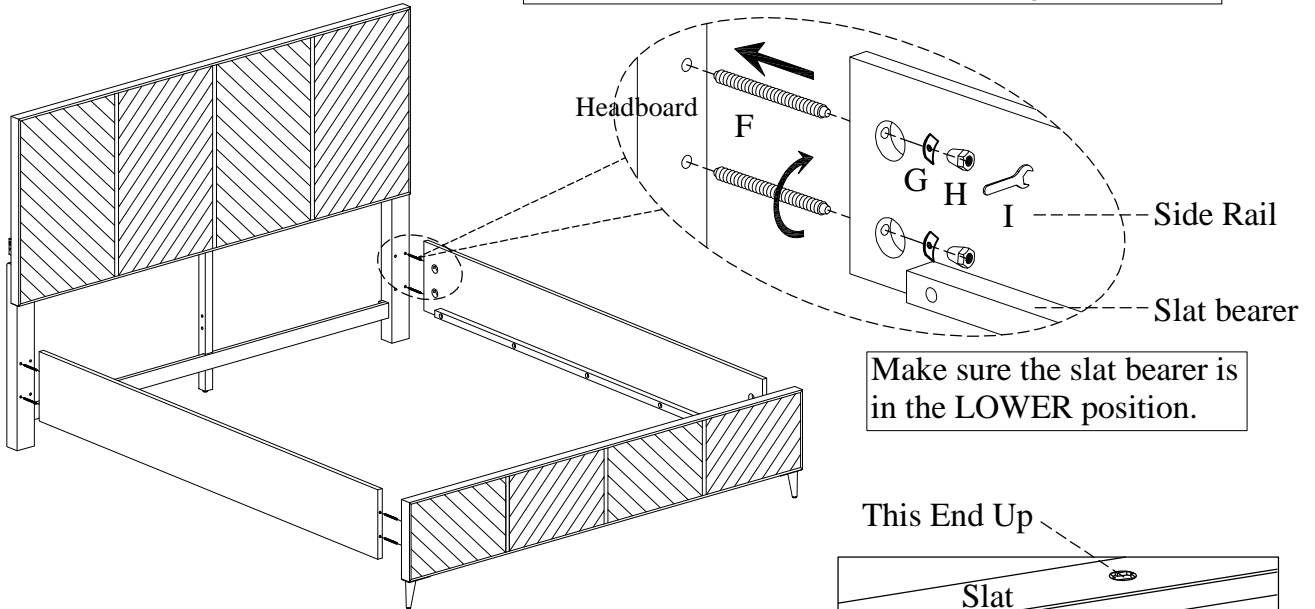

Make sure the slat bearer is in the LOWER position.

This End Up

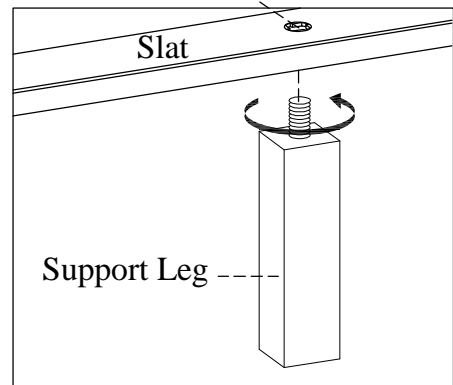

STEP 6: Attach the support legs to the slats as shown.

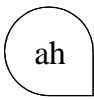

- ITEM NO: I644-415 King Panel HB
- I644-406 King Rails
- I644-410 Cal King Rails
- I644-407 King Low Profile FB

STEP 7: Arrange the slats on the slat bearers equally and attach to the slat bearers with wood screws (J).

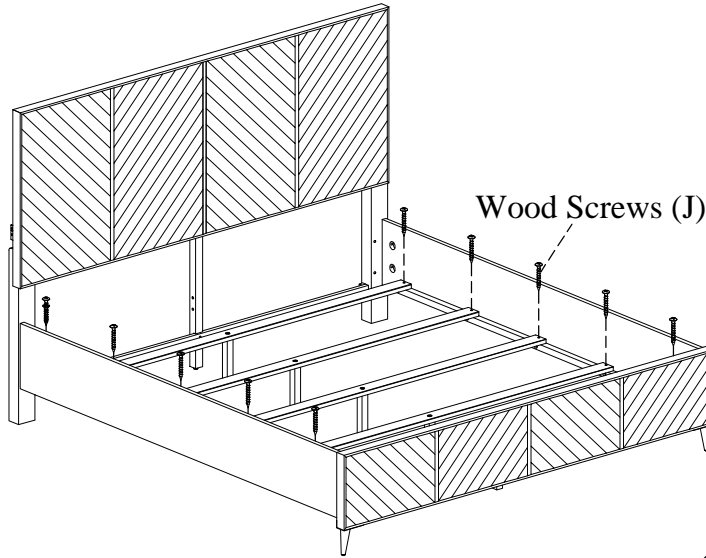

STEP 8: For Cal King bed, insert wood caps into the holes on headboard and footboard. For regular King bed, skip this step.

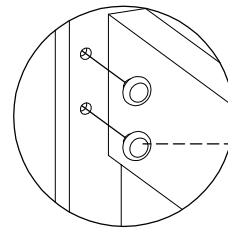

Wood Cap (K)

FUNCTIONALITY INSTRUCTION

