



ITEM NO: I644-9140 End Table

Thank you for purchasing this quality product. Be sure to check all packing material carefully for small parts that may come loose inside the carton during shipment.



TOOLS REQUIRED (NOT PROVIDED)

PHILLIPS SCREWDRIVER

HARDWARE LIST:

No.	Description	Sketch	Quantity
A	Bolt Ø5/16" x 1"		12 PCS
B	Lock Washer Ø5/16"		12 PCS
C	Flat Washer Ø5/16" x 3/4"		12 PCS
D	Allen Wrench 4mm		1 PC

COMPONENTS LIST:

No.	Description	Sketch	Quantity
1	Case		1 PC
2	Metal Leg		4 PCS

STEP 1: Put the case upside down on a soft surface.

STEP 2: Attach the metal legs by using 12 bolts (A), lock washers (B) and flat washers (C). Use the allen wrench (D) to tighten all bolts. Return the desk to the upright position.

FUNCTIONALITY INSTRUCTION

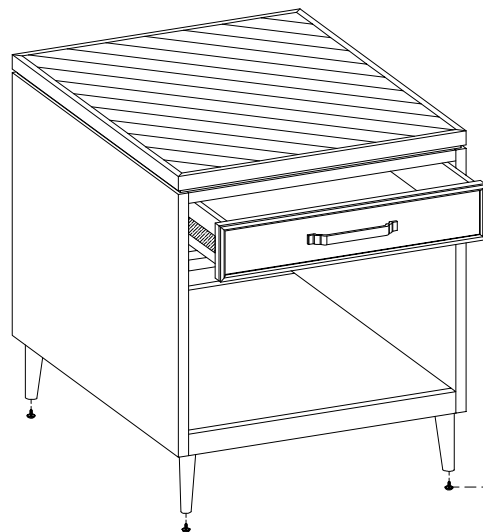
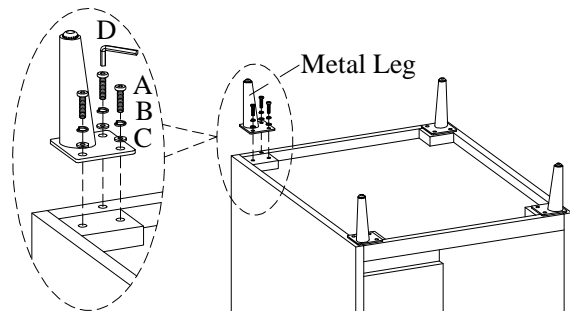

Adjust the leveler when necessary

Leveler on Legs

BEFORE USING THIS PRODUCT PLEASE READ, UNDERSTAND, AND FOLLOW THESE INSTRUCTIONS. Save these instructions for future reference.

FOR INDOOR USE ONLY