

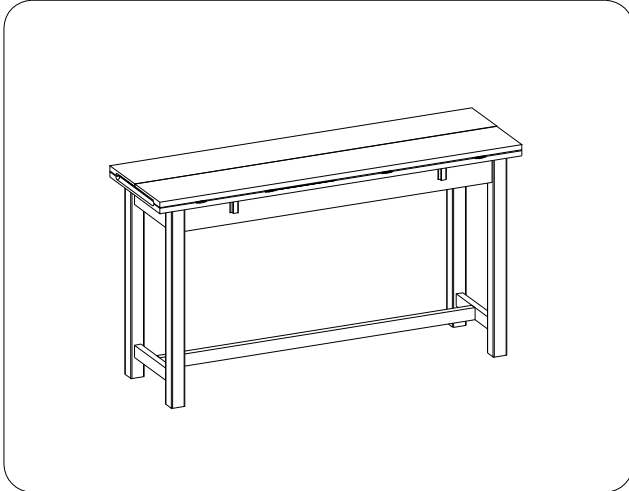

ITEM NO: I221-9151 Sofa Table

Thank you for purchasing this quality product. Be sure to check all packing material carefully for small parts that may come loose inside the carton during shipment.



### TOOLS REQUIRED (NOT PROVIDED)

PHILLIPS SCREWDRIVER

### COMPONENTS LIST:

No.	Description	Sketch	Quantity
1	Table Top		1 PC
2	Leg A		2 PCS
3	Leg B		2 PCS
4	Short Stretcher		2 PCS
5	Long Stretcher		1 PC

### HARDWARE LIST:

No.	Description	Sketch	Quantity
A	Bolt Ø5/16"*2"		8 PCS
B	Lock Washer Ø5/16"		8 PCS
C	Flat Washer Ø5/16" *3/4"		8 PCS
D	Allen Wrench 4mm		1 PC
E	Wood Screw M4*1-3/4"		6 PCS

**STEP 1:** Put the table top face down on a soft surface. Attach the legs to table top by using 4 bolts(A), lock washers(B) and flat washers(C). Do not completely tighten bolts.

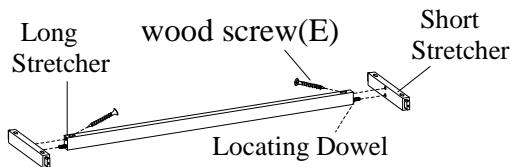
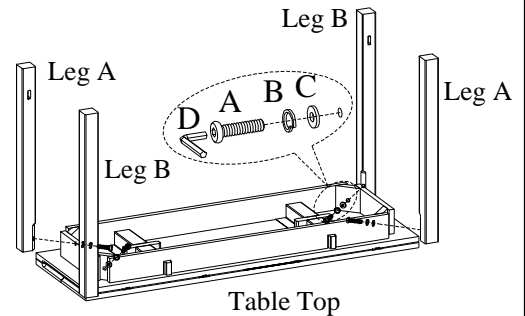

**STEP 2:** Attach the long stretcher to short stretchers with wood screw(E).

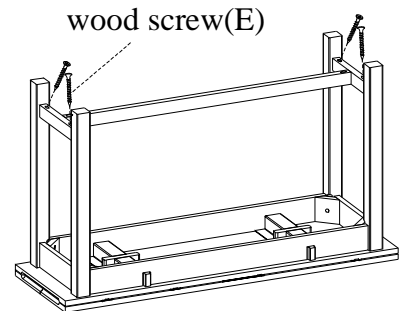

**STEP 3:** Attach the stretchers to legs with wood screw(E). Completely tighten all bolts. Turn the assembled table to the upright position.

### FUNCTIONALITY INSTRUCTION

Expandable top Panel  
Pullout Supports for Expandable top Panel

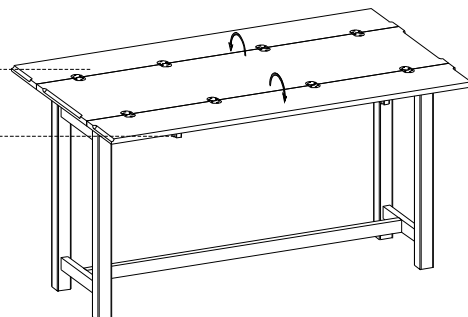

BEFORE USING THIS PRODUCT PLEASE READ, UNDERSTAND, AND FOLLOW THESE INSTRUCTIONS. Save these instructions for future reference.

FOR INDOOR USE ONLY